

We thank you for having chosen one of our products, the fruit of technological experience and of continual research for a superior quality product in terms of safety, dependability, and service.

In this manual you will find all the information and useful suggestions to use your product with the maximum safety and efficiency.



***We highly recommend to turn to our Authorized Service Centre for the installation and the first ignition of the device as it not only carries out the installation perfectly but also verifies the regular operation of it.***

- Incorrect installation, incorrectly performed maintenance, improper use of the product release the manufacturer from every eventual damage derived from the use of the stove.
- The unit cannot be used as an incinerator. Do not use fuels other than pellets.
- This manual has been realized by the manufacturer and constitutes an integral part of the product and must remain with it during its entire lifetime. If the product is sold or transferred, be sure that the booklet is present since the information contained in it are addressed to the buyer, and to all those persons of various titles who complete the installation, use and maintenance.
- Carefully read the instructions and the technical information contained in this manual, before proceeding with the installation, use, and any operation on the product.
- The observance of the indications contained in the present manual guarantees the safety of people and the product, the economy of use and a longer functioning lifetime.
- Although the carefully studied design and the risk analysis done by our company has permitted the realization of a safe product, in any case, before effecting any operation on the stove, it is recommended to keep said manual available and pay scrupulous attention to the instructions written therein.
- Be very careful when moving the ceramic details where present.
- Check the precise flatness of the pavement where the product will be installed
- The wall where the product will be placed must not be constructed in wood, or in any case, made of an inflammable material, and in addition it is necessary to maintain a safety distance.
- While the stove is in operation, several parts of the stove (door, handle, sides) can reach high temperatures. Therefore pay attention and use the proper precautions, above all in the presence of children, elderly or disabled persons, and animals.
- Assembly must be performed by authorized persons (Authorized Assistance Center).
- Diagrams and drawings are furnished for the purpose of illustration; the manufacturer, with the intent of pursuing a policy of constant development and renewal of the product can, without any notice, make any modifications that are believed opportune.
- When the stove is working at its maximum speed, it is strongly suggested to wear gloves while handling with the door for pellets loading and the door handle.
- It is prohibited to install in bedrooms or in explosive environments.
- Only use replacement parts recommended by the supplier.



***Never cover the body of the stove in any way or obstruct the openings placed on the upper side when the device is operating. All our stoves are trial lighted on the construction line.***

**In the event of a fire, disconnect the power supply, use an extinguisher and call the fire fighters if necessary. After that contact the Authorized Assistance Center.**

This instruction booklet is an integral part of the product: make sure that it always accompanies the appliance, even in case of transfer to another owner or in the case of transfer to another place. In the event of damage or loss, request a copy from the area technician.

These symbols indicate specific messages in this booklet:



**ATTENTION:**

This warning sign indicates that the message to which it refers should be carefully read and understood, **because failure to comply with what these notices say can cause serious damage to the stove and put the user's safety at risk.**



**INFORMATION:**

This symbol is used to highlight information which is important for proper stove operation. Failure to comply with these provision will compromise use of the stove and its operation will not be satisfactory.

## Norms and declarations of conformity

Our company declares that the stove conforms to the following norms for the EC European Directive labelling:

- 2014/30 UE (regulation EMCD) and following amendments;
- 2014/35 UE (Low Voltage Directive) and following amendments;
- 2011/65 EU (RoHS 2 directive);
- The Rules of Construction Products (CPR-Construction Products Regulation) No. 305/2011 regarding the construction world;
- For installations in Italy, please refer to UNI 10683/98 or following changes. For the water-thermo-sanitary equipment, let the installer give you the conformity declaration in compliance with L. 37/2008. While installing the unit respect the local, national and European rules;
- EN 55014-1; EN 55014-2; EN 61000-3-2; EN 61000-3-3; EN 60335-1; EN 60335-2-102; EN 62233, EN 50581.

### Safety information

Please carefully read this use and maintenance manual before installing and operating the stove!

If clarification is needed, please contact the dealer or the Authorized Assistance Center.

- The pellet stove must only be operated in living environments. This stove, being controlled by an electronic board, permits a completely automatic and controlled combustion; the exchange, in fact, regulates the lighting phase, 5 power levels and the shut down stage, guaranteeing the safe operation of the stove.
- The basket used for combustion allows most of the ash produced by the combustion of the pellets to fall into the collection compartment. Nevertheless, check the basket daily, given that not all pellets have high quality standards (use only quality pellets recommended by the manufacturer).
- In order to achieve the test report results, please load the performance parameters retained by the manufacturer and the qualified technician. They will use these parameters once verified that, during the installation, it is possible to reproduce the laboratory conditions.

### Responsibility

With the delivery of the present manual, we decline all responsibility, both civil and penal, for accidents deriving from the partial or total lack of observance of the instructions contained herein.

We decline every responsibility derived from improper use of the stove, from incorrect use by the user, from unauthorized modifications and/or repairs, from the use of replacement parts that are not original for this model.

The manufacturer declines every civil or penal, direct or indirect responsibility due to:

- Lack of maintenance;
- Failure to observe the instructions contained in the manual;
- Use in non-conformity with the safety directives;
- Installation in non-conformity with the norms in force in the country;
- Installation by unqualified or untrained personnel;
- Modifications and repairs not authorized by the manufacturer;
- Use of non-original replacement parts;
- Exceptional events.



- Use only wood pellets;
- Keep / store the pellets in a cool dry place;
- Never pour pellets directly on the hearth;
- The stove must only be fed with quality 6 mm diameter pellets, A1 certified according to the UNI EN ISO 17225-2 regulations;
- Before making the electrical connection of the stove the discharge tubes must be connected with the flue;
- The protective grill placed inside the pellet container must never be removed;
- The environment where the stove is installed must have a sufficient exchange of air;
- It is forbidden to operate the stove with the door open or the glass broken;
- Do not use the stove as an incinerator; the stove should be used only for the intended purpose;
- Any other use is considered improper and therefore dangerous. Do not put in the hopper other than wood pellets;
- When the stove is operating, the surfaces, glass, handle and tubes become very hot: during operation do not touch these parts without adequate protection;
- Keep the fuel and other inflammable materials off the stove.

## Charge pellet

Fuel is loaded from the upper part of the stove by opening a door. Pour the pellets in the hopper; This is easier if performed in two steps:

- Pour half of the contents of the bag into the hopper and wait for the fuel to settle on the bottom.
- Then pour in the second half;
- Keep the cover closed , after loading the pellets , the lid of the fuel tank;
- Before closing the door load-pellet make sure that there are no residues of pellets around the seal. If carefully cleaned to avoid compromising the seals.

The stove is a product by heating, presents the external surfaces particularly hot. For this reason, we recommend extreme caution when operating in particular:

- Do not touch the stove body and the various components, do not approach the door , it could cause burns;
- Do not touch the exhaust fumes;
- Do not perform any type of cleaning;
- Do not dump the ashes;
- Do not open the ash tray;
- Be careful that children do not come near;



**Never remove the protection grille in the hopper. When filling, do not let the sack of pellets touch any hot surfaces.**



## Instructions for safe and efficient use

---

- The appliance is not intended for use by persons (including children) with reduced physical, sensory or mental capacities, or lack of experience or knowledge, unless they have been given through the intermediary of a person responsible for their safety, supervision or instruction concerning use of the appliance;
- Do not use the stove as a ladder or scaffold;
- Do not put clothes to dry on the stove. Any clothes hangers and suchlike must be kept a suitable distance from the stove. - Risk of fire
- Carefully explain that the stove is made from material subjected to high temperatures for the elderly, the disabled, and in particular for all children, keeping them away from the stove during operation
- Do not touch the stove with wet hands: the stove has electrical components that could produce sparks if handled incorrectly.
- Never open the glass door of the pellet stove while the stove is in operation.
- The stove must be connected to an electrical system equipped with an earthing conductor in accordance with regulations;
- The system must be of adequate electrical power declared the stove;
- Do not wash the inside of the stove with water. The water could damage the electrical insulation, causing electric shock;
- Do not expose your body to hot air for a long time. Do not overheat the room you are in and where the stove is installed. This can damage the physical conditions and cause health problems;
- Do not expose to direct the flow of hot air plants or animals;
- The pellet stove is not a cooking element;
- External surfaces during operation can become very hot. Do not touch them except with the appropriate protection;
- The plug of the device power cable must be connected only after installation and assembly of the device and must remain accessible after installation, if the unit is not provided of a double-pole switch suitable and accessible.
- Pay attention that the power cord (and any other cables external to the appliance) do not touch hot parts.
- Do not lay objects, glasses, infusers, room perfumers on the thermostove, they could be damaged or to damage the thermostove (in this case de warranty does not respond).



**The stove is equipped with a safety device to prevent operation with dangerous negative pressure in the combustion chamber caused for example by unfavourable climatic situations or blockages in the flue. If intervening on this device, do not tamper with it and wait for the climatic situation to allow the flue to return to a negative pressure that would guarantee correct operation of the stove. If the stove is installed in particularly windy situations for long periods of time which would prevent daily use of the stove, the smoke extractor speed can be increased to guarantee correct negative pressure in the combustion chamber. This operation must be carried out by an authorized technician.**

---

**In order to achieve the test report results, please load the performance parameters retained by the manufacturer and the qualified technician. They will use these parameters once verified that, during the installation, it is possible to reproduce the laboratory conditions.**

---

## Operating area

For proper functioning and a good temperature distribution, the stove should be positioned in a location where it is able to take in the air necessary for combustion of the pellet (about 40 m<sup>3</sup>/h must be available, as laid down in the standard governing the installation and in accordance with local national standards).

The volume of the room must not be less than 30 m<sup>3</sup>.

The air must come in through permanent openings made in walls (in proximity to the stove) which give onto the outside, with a minimum cross-section area of 100 cm<sup>2</sup>.

These openings must be made in such a way that it is not possible for them to be obstructed in any way. Alternatively, the air can be taken from rooms adjacent to the one which needs ventilating, as long as they are provided with an air intake from the outside, and are not used as bedrooms or bathrooms, and provided there is no fire risk such as there is for example in garages, woodsheds, and storerooms, with particular reference to what is laid down in current standards.



**It is not permissible to install the stove in bedrooms, bathrooms, or in a room where another heating appliance is installed (fireplace, stove etc.) which does not have its own independent air intake.**

**Locating the stove in a room with an explosive atmosphere is prohibited.**

**The floor of the room where the stove is to be installed must be strong enough to take its weight. If walls are flammable, maintain a minimum distance of 20 cm at the rear (A), of 40 cm at the side (B) and 100 cm at the front. If the room contains objects which are believed to be particularly delicate, such as drapes, sofas and other furniture, their distance from the stove should be considerably increased.**



**If the stove is installed on a flammable floor it must be interposed with a slab of insulating material to heat it protrudes at least 20 cm on the sides and 40 cm on the front.**



**In the presence of wood floors, install a floor protection surface in compliance with the rules in force in the country**

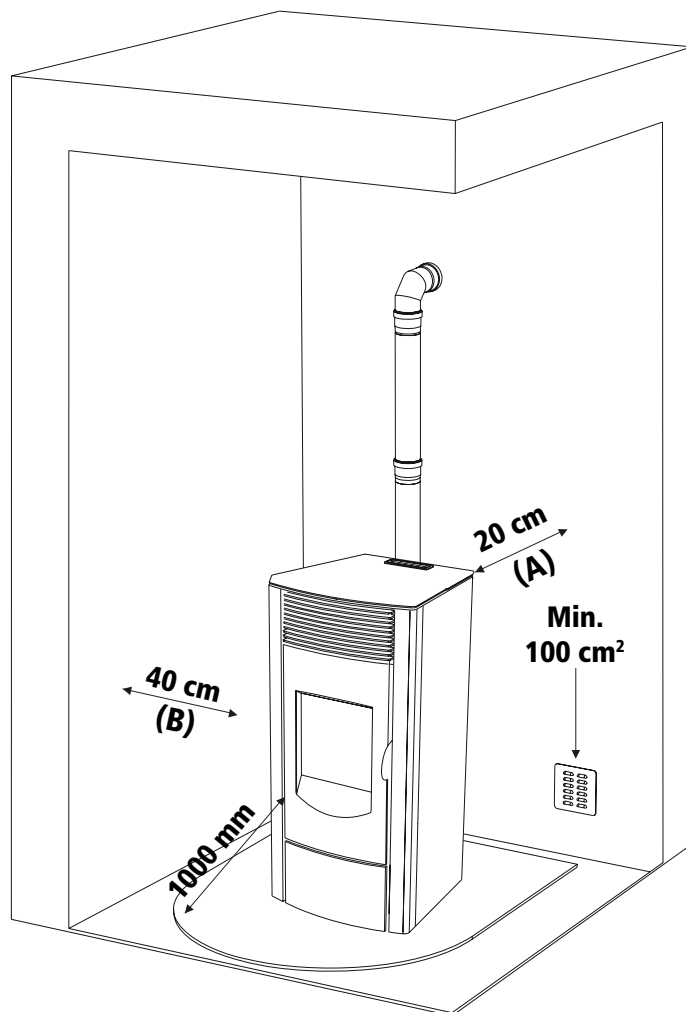

### Connection to the external air intake

It is essential that at least as much air must be able to flow into the room where the stove is installed as is required for proper combustion in the appliance and for the ventilation of the room. This can be effected by means of permanent openings in the walls of the room to be ventilated, which give onto the outside, or by single or collective ventilation ducts. For this purpose, on the external wall near the stove, a hole must be made with a minimum free cross-section of 100 cm<sup>2</sup>. (equivalent to a round hole of 10 cm diameter or a square hole 10x10 cm) protected by a grille on the inside and the outside.

The air intake must also:

- communicate directly with the room where the stove is installed
- be protected by a grille, metal mesh or suitable guard, as long as this does not reduce the area below the minimum.
- positioned in such a way as to be impossible to obstruct.

## Connection to the flue pipe

The flue pipe must have internal dimensions not larger than 20x20 cm, or diameter 20 cm. In the event of larger dimensions, or of the flue pipe being in poor condition (for example cracks, poor insulation, etc.), it is advisable to fit a stainless steel pipe of suitable diameter inside the flue pipe throughout its length, right up to the top.

Check with suitable instruments that there is a draught between 3 Pa and 12 Pa. This type of connection ensures the evacuation of the fumes even in the event of a temporary power cut.

At the bottom of the flue pipe, provide an inspection cap to allow periodic checking and cleaning, which must be done annually. Make a gas-tight connection to the flue pipe, using pipes and connectors as recommended by us.

You must ensure that a windproof cowl should be fitted which complies with the standards in force (Fig. 1).

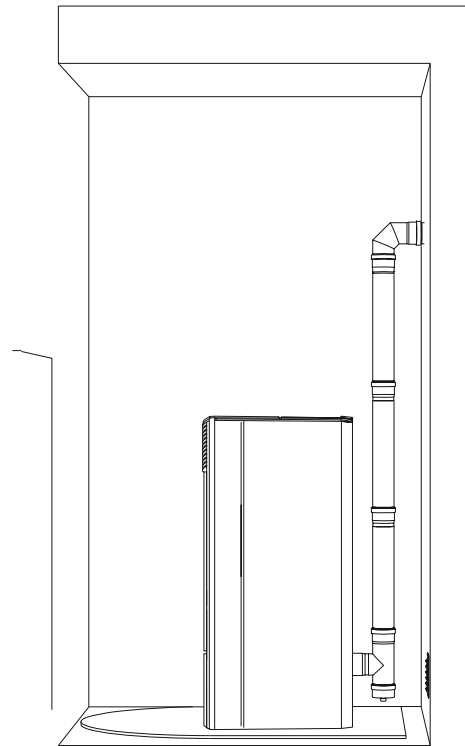

Fig. 1

## Connection to an external flue with insulated or double-wall pipe

The only type of pipe which is permissible is insulated (double-walled) stainless steel, smooth on the inside, fixed to the wall. Flexible stainless steel pipe must not be used. At the bottom of the flue pipe, provide an inspection cap to allow periodic checking and cleaning, which must be done annually. Make a gas-tight connection to the flue pipe, using pipes and connectors as recommended by us. You must ensure that a windproof cowl should be fitted which complies with the standards in force.

Check with suitable instruments that there is a draught between 3 Pa and 12 Pa (see table page 11).

## Connection to the flue pipe

For proper functioning, the connecting pipe between the stove and the chimney or flue duct must have a slope of not less than 3% in the horizontal stretches, the length of which must not exceed 2 metres and the vertical distance between one tee connector and another (change of direction) must not be less than 1,5 m.

Check with suitable instruments that there is a draught between 3 Pa and 12 Pa. At the bottom of the flue pipe, provide an inspection cap to allow periodic checking and cleaning, which must be done annually.

Make a gas-tight connection to the flue pipe, using pipes and connectors as recommended by us. You must ensure that a windproof cowl should be fitted which complies with the standards in force.

## Fireplace flue gas

Avoid contact with combustible materials (example: wooden beams) and in any case provide for their insulation with flame retardant material. In case of pipe penetrations through roofs or walls is recommended to use special kits crossing, certificates, are available commercially. In the event of a chimney fire, turn off the stove, disconnect from the network and never open the door. Then call the authorities.

## The chimney cap

The chimney cap must respect the following requirements:

- It must have the equivalent diameter and internal form of the flue.
- It must have a useful outlet diameter of not less than double that of the flue.
- The chimney cap on the roof or that remains in contact with the outside (for example, in case of open lofts or attics), must be covered with elements in brick or tile and must, in any case, be well insulated.
- It must be constructed to prevent rain, snow, and extraneous bodies from entering the flue and so that the discharge of the products of combustion is not inhibited by wind from any quarter or strength (wind-proof chimney cap).
- The chimney cap must be positioned in such a way as to guarantee the adequate dispersion and dilution of the products of combustion and in any case, must be out of the reflux zone. This zone has different dimensions and forms according to

the angle of inclination of the roof so it is necessary to adopt minimum heights (Fig. 2).

- The chimney cap must be a wind-proof type and must be above the ridge.
- Eventual structures or other obstacles that are higher than the chimney cap must not be too close to the chimney cap itself.
- The device should not be installed in the flue shared.

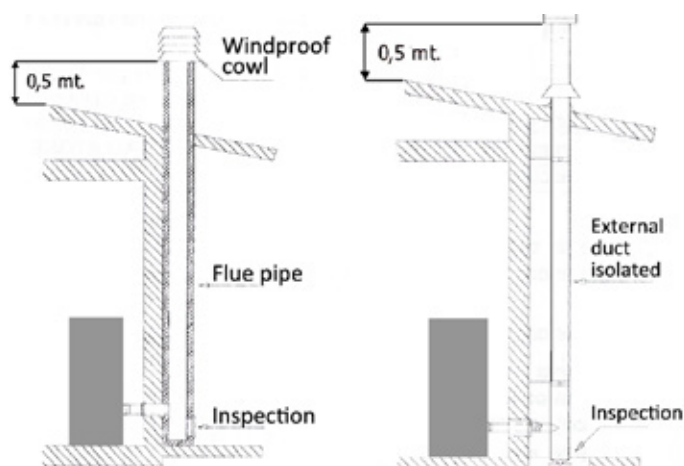

Fig. 2: connection to the flue pipe.

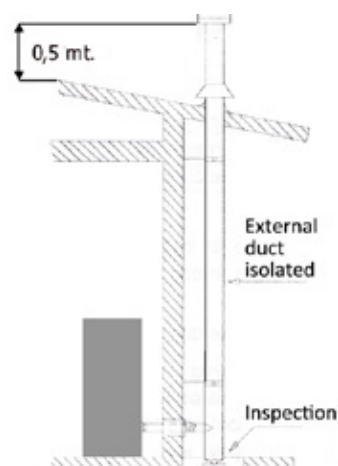

Fig. 3: connection to an external flue with insulated or double-wall pipe.

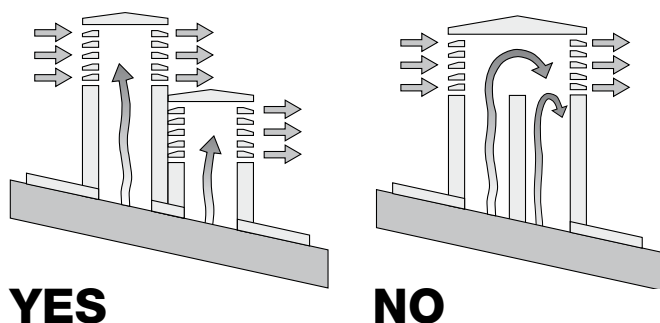

Fig. 5: Characteristics of chimney

### Connection of the canalization pipe (Where present)

The two air outputs placed on the back of the stove only one tube of 80mm diameter and 8 linear meters of maximum length.

You have to consider a loss around 1 meter of the linear tract for each bend of 45° (ex.: maximal distance without bends: 8 meters; maximal distance with one bend  $8-1=7$  meters).

### Distance to objects

It is also recommended to keep the pellets and all flammable materials at a suitable distance from the stove.

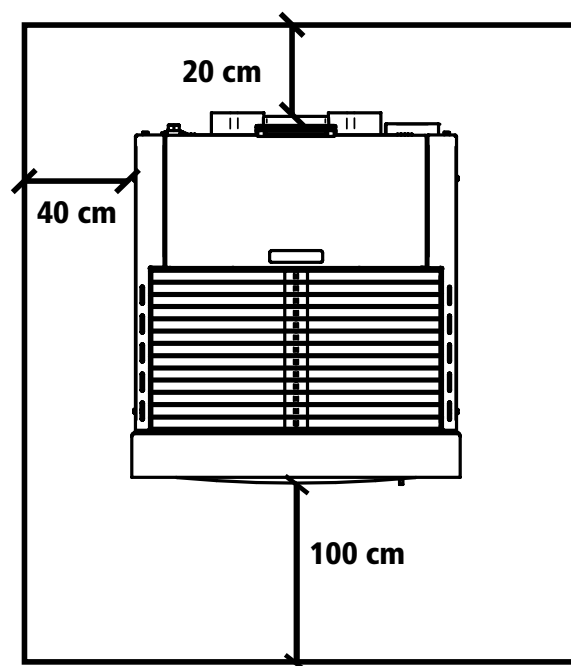





### REMARKS:

- the appliance must be installed by a qualified technician in possession of the technical and professional requirements according to the DM37/2008 that, under its responsibility, to ensure compliance with the rules of good technique.
  - you need to keep in mind all laws and national, regional, provincial and municipal laws of the country in which you installed the device
  - check that the floor is not flammable: if necessary use a suitable platform
  - in the room where the generator must be installed to heat must not pre-exist or be installed with an extractor hood or ventilation ducts of the collective type.
- Should these devices be located in adjacent rooms communicating with the installation, and 'prohibited the simultaneous use of the heat generator, where there is a risk that one of the two rooms being placed in depression than the other
- it is not permissible to install in bedrooms or bathrooms.

The remote control (Fig. 3) used to adjust water temperature power and the on/off functions for the pellet stove.

To start the stove, press key  and the stove will automatically enter the starting phase.

Press keys  + (1) and  - (2) to adjust temperature, and use keys  + (6) and  - (5) to adjust operating power.

To turn off the stove, hold down key .

To replace the 3 volt battery located on the back of the remote control, pull the centre of the cover and the lever on the side of the same, replace the battery observing the correct polarity (Fig. 4)



Fig. 3



Fig. 4

## Technical Specification

### Mod. 12 / 12 C

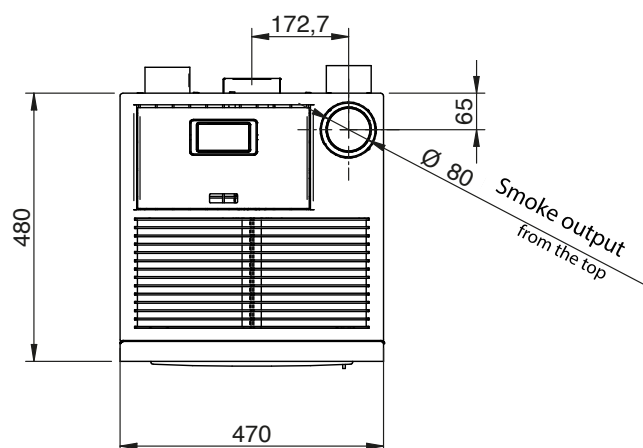
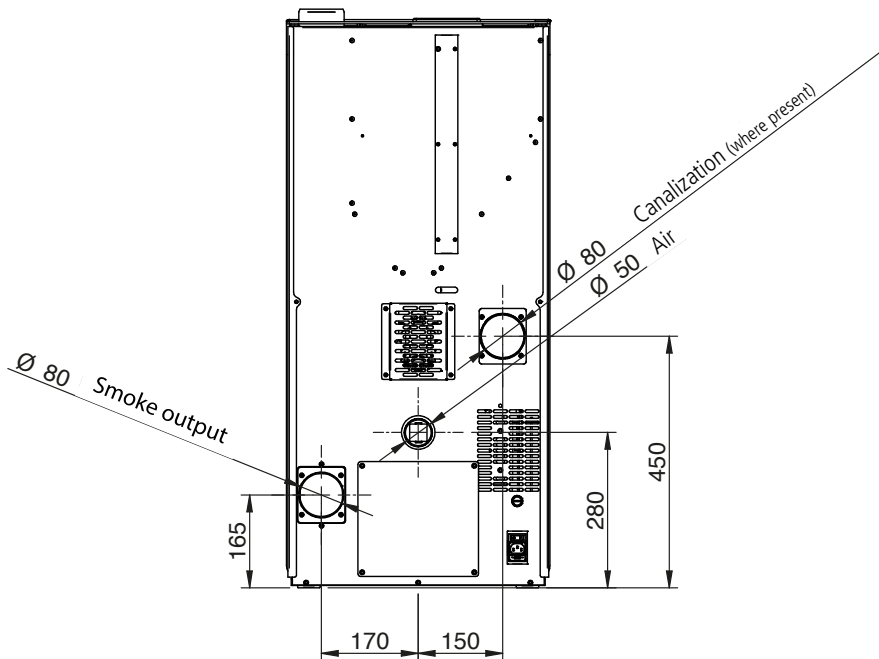
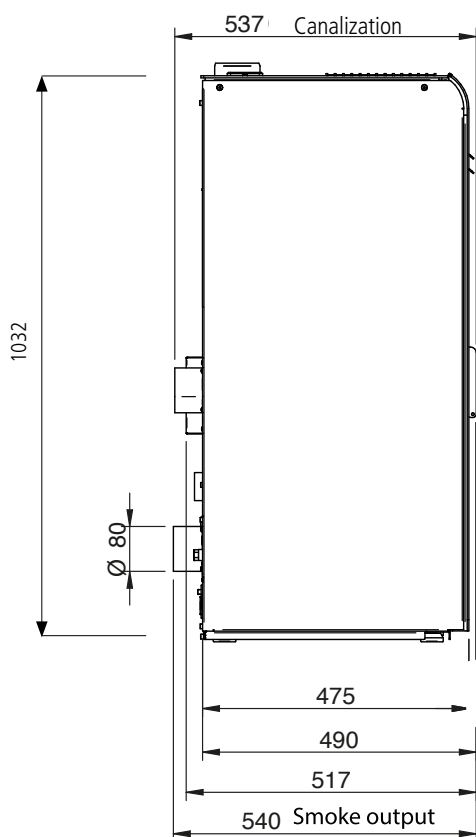

### REMARKS:

- measurements are approximate and may vary based on to the aesthetics of the stove
- the positions of the tubes in the rear view are indicative and tolerance of +/- 10 mm
- measures with a tolerance of about 10 mm

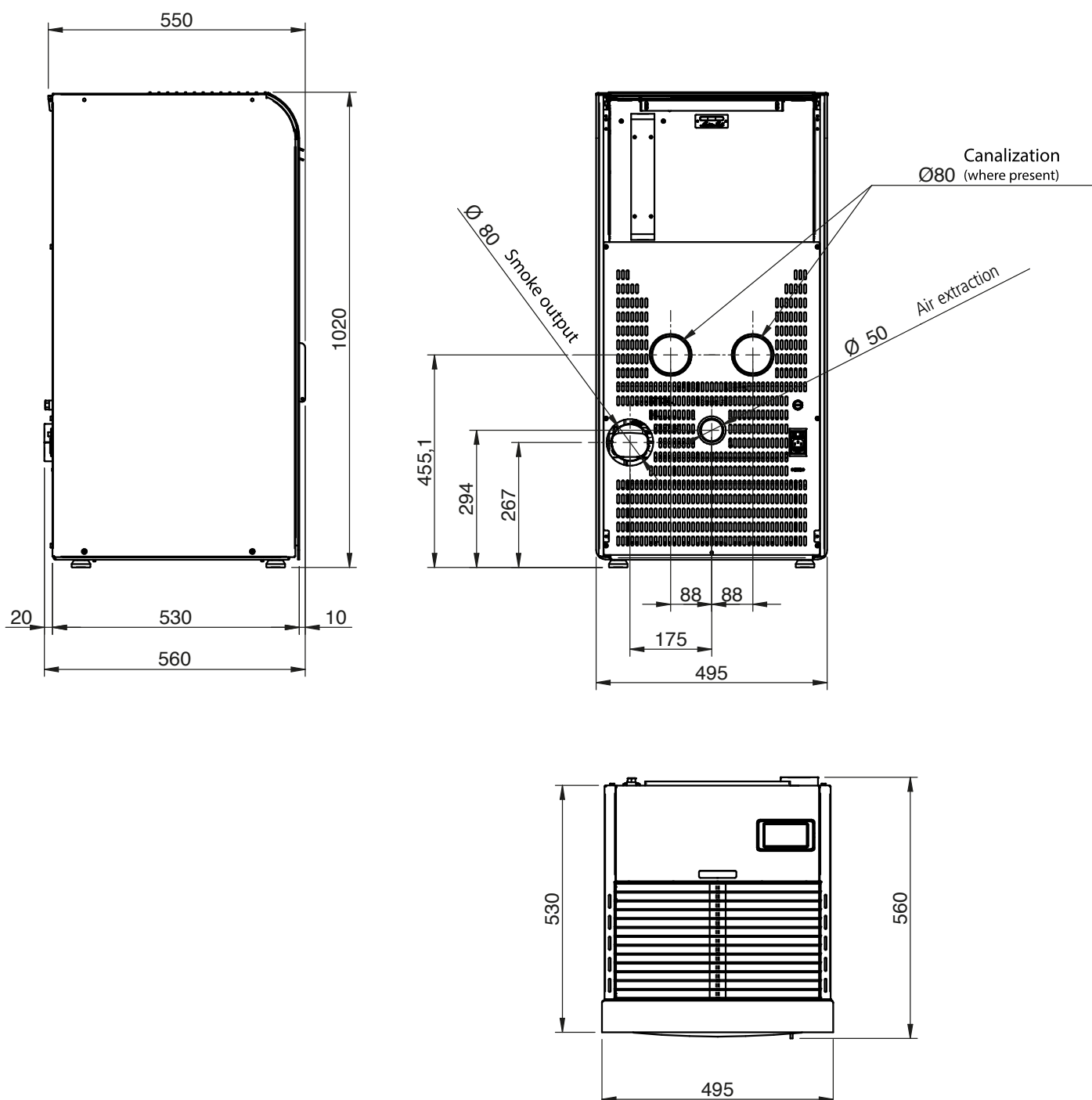

## Mod. 14 / 14 C

**REMARKS:**

- measurements are approximate and may vary based on to the aesthetics of the stove
- the positions of the tubes in the rear view are indicative and tolerance of +/- 10 mm
- measures with a tolerance of about 10 mm

## Mod. 16 / 16 C

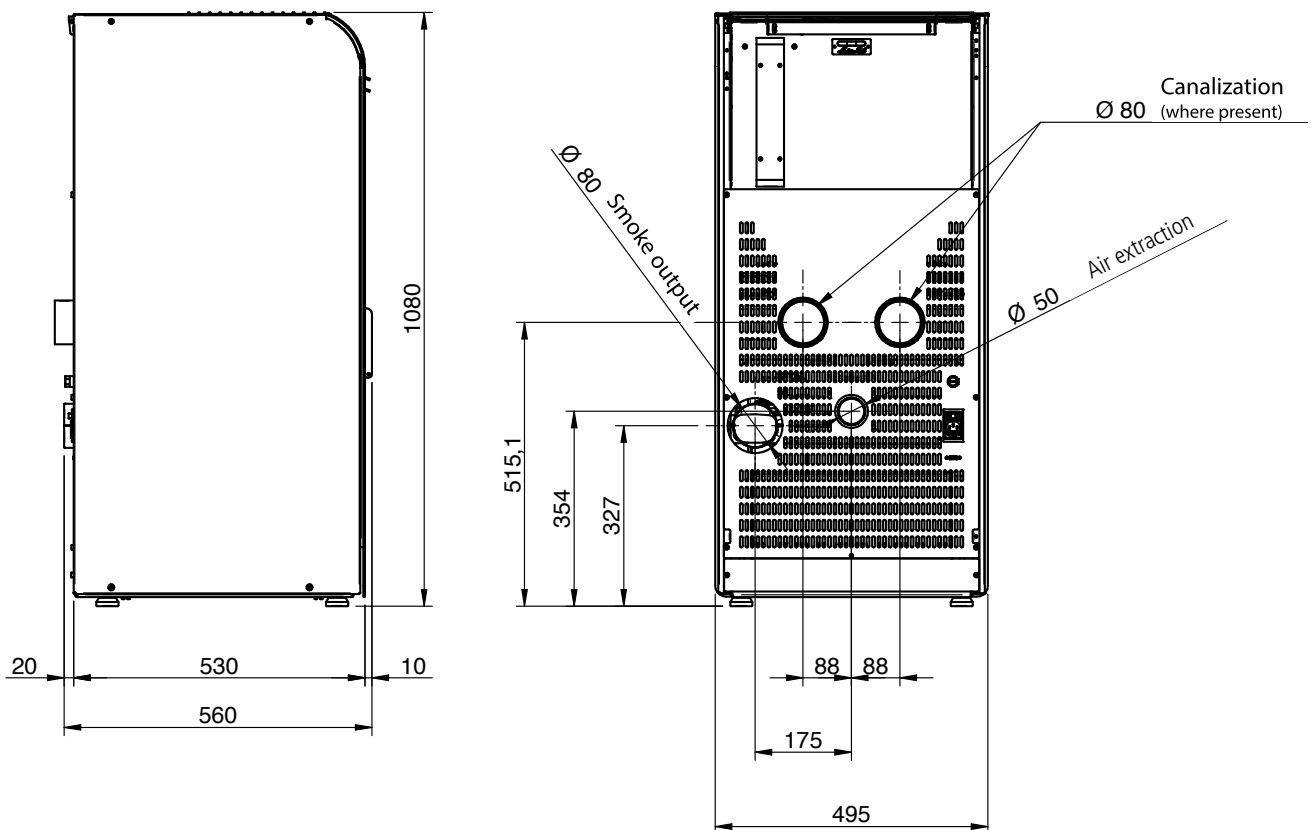
**REMARKS:**

- measurements are approximate and may vary based on to the aesthetics of the stove
- the positions of the tubes in the rear view are indicative and tolerance of +/- 10 mm
- measures with a tolerance of about 10 mm

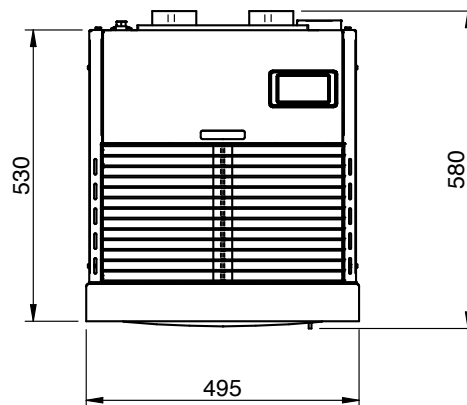
**Pellet**

The pellets are cylinders of compressed wood, produced from sawdust and wood processing (chips and sawdust), generally produced by sawmills and carpenters. The binding capacity of the lignin contained in wood, allows to obtain a compact product without adding additives and foreign chemicals to the wood, is therefore obtained a natural fuel with high yield.

The use of expired pellets or any other unsuitable material can damage parts of the thermostove and impair proper operation: this can lead to the termination of the guarantee, and its producer responsibility.

**For our products use pellets diameter 6 mm, length 30 mm and a maximum of 8% and A1 certified according to the UNI EN ISO 17225-2 standard. Keep the pellets away from heat sources and not in humid environments or with explosive atmosphere.**



PARAMETER	M. UNITS	MOD. 12 / 12 C	MOD. 14 - 14 C	MOD. 16 / 16 C
Heat input	kW	12,3 - 5,2	13,2 - 3,8	16,3 - 3,4
Nominal heat output	kW	11,1	12,5	15,2
Reduced heat output	kW	4,8	3,7	3,7
CO concentration at nominal reference (13% O <sub>2</sub> )	mg/m <sup>3</sup>	52	104,82	94,85
CO concentration at reduced reference (13% O <sub>2</sub> )	mg/m <sup>3</sup>	108	409,5	409,5
Nominal efficiency	%	90,2	94,76	93,48
Reduced efficiency	%	93,5	98	98
Flue gas flow rate (min-max)	g/s	4,48 - 7,55	2,83 - 7,29	2,83 - 8,53
Draft advised (min-max)	Pa	3 - 11	3 - 12	3 - 12
Flue gas temperature (min-max)	°C	99,4 - 176,3	46 - 113	46 - 140
Tank capacity	Kg	25 - 16	23	23
Recommended fuel	(ø x H) mm	pellet 6x30	pellet 6 x 30	pellet 6 x 30
Diameter smoke outlet tube	mc	300 - 310	330 - 350	380 - 400
Canalization diameter	mm	80	80	80
Diameter air intake	mm	80	80	80
Nominal voltage	mm	50	50	50
Tensione nominale	V	230	230	230
Nominal frequency	Hz	50	50	50
Assorbimento elettrico accensione	W	290	400	400
Assorbimento elettrico min-max	W	100 - 45	135 - 140	140 - 145
Stove weight	Kg	85 (12) / 87 (12C)	145 (14) / 147 (14 C)	151 (16) - 153 (16 C)
Energetic Class		A+	A+	A+
IEE		126	124	123
Environmental Certificate Decree n° 186 del 7/11/2017		★★★★☆	★★★★☆	★★★★☆
N° Test Report		K2457 2018 T1	K1905 2016 T1	K1905 2016 T1
Dust at 13% O <sub>2</sub> Reference of nominal heat output	mg/m <sup>3</sup>	19	13	12

**It is recommended that the control of emissions after installation.**

## Stove start up



Remove any components which might burn from the firebox and from the glass (various instructions and adhesive labels).

### Charge pellet

Fuel is loaded from the upper part of the stove by opening a door. Pour the pellets in the hopper. This is easier if performed in two steps:

- Pour half of the contents of the bag into the hopper and wait for the fuel to settle on the bottom.
- Then pour in the rest.



Never remove the protection grille in the hopper. When filling, do not let the sack of pellets touch any hot surfaces.



The brazier should be cleaned before each starting.

### First lighting of the stove

- Before switching on, make sure that the grate is clean and empty of any pellet residues from previous combustions. Otherwise make sure you empty and clean it
- Fill the container 3/4 full with the pellets recommended by the manufacturer
- Connect the stove to an electrical outlet with the cable that has been supplied
- Press the lighting switch located on the back part of the stove
- The upper display will read **"OFF"**
- Press the button  for 2 seconds. After a few moments the smoke extractor and the lighting resistor will start and the display will read **"START"**; The led resistance is switched on
- After 1 minute the display will read **"LOAD PELLETS"**, the stove will load the pellets and continue lighting the resistor
- Once the appropriate temperature has been reached the display will read **"FLAME LIGHT"**: this means that the stove has begun the last phase in lighting, at the end of which the stove will be completely operational; The led resistance is switched off
- After some minutes the display will show the words **"WORK"** alternating room temperature and current working power. The stove is now completely on
- When the stove reaches the set temperature, the display will show **"MODULATION"**.



Before lighting a small amount of smoke may fill the combustion chamber.



We highly recommend to turn to our Authorized Service Centre for the installation and the first ignition of the device as it not only carries out the installation perfectly but also verifies the regular operation of it. During the first lighting the environment should be well ventilated since during the first hours of operation unpleasant odours could develop due to the physical stabilizing of the paint and from the grease in the tube bundle.

---

## Stove switching off

To switch off the stove, press the key  on the control board until you read **"CLEANING FINAL"** on the display. After the stove has been switched off, the fan continues working for a set time in order to grant a fast smokes exhaust from the combustion chamber.

If you have a model with remote control, you just need to switch the remote control off keeping the key pressed for 2 seconds and confirming the selection pressing the key SEND.

If you try to switch on the stove during this phase, the display will show **"WAITING COOLING"** (that means wait for cooling) in order to inform you a switching off phase is running. Wait until the cooling phase is completely off and the display shows **"OFF"** before starting a new light up.

### REMARKS:

- Do not continuously turn the stove on and off as this could provoke sparks that could shorten the life of the electrical components.
- Do not touch the stove with wet hands: the stove has electrical components that could produce sparks if handled incorrectly. Only authorized technicians can resolve possible problems.
- Do not remove any screws from the fire chamber without first lubricating them well.
- Never open the glass door of the pellet stove while the stove is in operation.
- Be sure that the brazier basket is positioned correctly.
- The flue system must be suitable for inspection. If it cannot be removed, it must have some holes for inspection and cleaning.

# Control board

1. Temperature increase
2. Temperature decrease
3. Key SET
4. Key on/off
5. Operating power decrease
6. Operating power increase



## Functional keys

1. Temperature increase: using this key you can increase the wished temperature from a min. value of 7°C to a max. value of 40°C.

2. Temperature decrease: using this key you can reduce the wished temperature from a max. value of 40° C to a min. value of 7°C.

3. Key SET: push this button to enter the programming menu of the stove.

4. Key on/off: keep this button pushed  for two seconds to switch the stove on or off.

5. Operating power decrease: using this key you can reduce the working power from a max. value of 5 to a min. value of 1.

6. Operating power increase: using this key you can increase the working power from a min. value of 1 to a max. value of 5.

## Function indicators

### Chronothermostat

This signalises that the automatic single or daily switching on or off of the stove is on. The automatic programming can be set only using the remote control.

### Resistance indicator

This works only when the stove is lighting up to indicate that the resistance is warming the air to burn pellets.

### Endless screw

This switches on every time pellets are being loaded in the stove.

### Smokes extractor

This signalises the smokes ventilator is working.

### Exchanger

This indicates the room ventilator is working.

### Alarm indicator



This lights up in the event of an alarm or functioning defect. You can read the kind of signalised alarm on the display.

### Remote control reception

## Stove setting

### How to change the wished room temperature



You can change the temperature whenever you want.

Press the keys  (1) and  (2) to modify the wished value. When you stop working on the Set temperature menu for a while, the stove will automatically leave the menu itself.



### How to change the operating power

You can change the operating power from a min. value of 1 to a max. value of 5. You can also choose the "Auto".

Press the key  (6) to increase or press  (5) to reduce it.

When you stop working on the power menu for a while, the stove will automatically leave the menu itself.

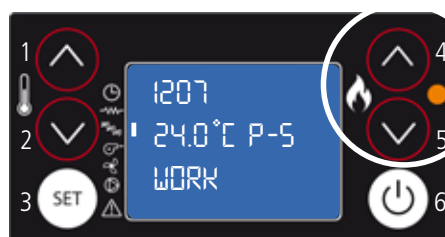

## Fan speed adjustment channeling (if any)

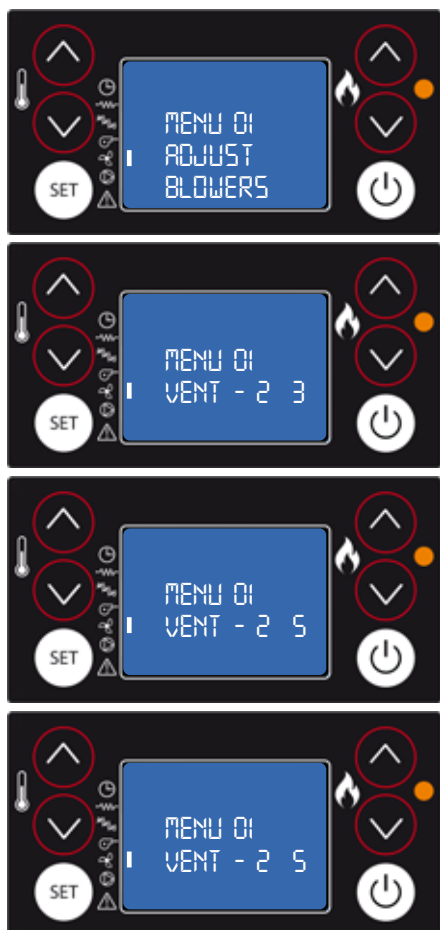

### Menu 01 - Setting fans

1. Press the SET button.  
Will appear on the display MENU 01 SETTING FANS.
2. Pressing the SET key to access the menu to set the speed of your funnel fans.
3. Set the speed using the buttons 1 and 2. With key 1 you set the speed of the right fan, with key 2 you set the speed of the left fan.
4. To turn off the fans of the funnel, set the speed to 0.

## Display informations



**OFF**  
The stove is off.



**FLAME LIGHT**  
The stove starts loading pellets in the brazier.  
Smokes extractor and gear motor are on.



**START**  
The stove is switching on.  
Resistance and smokes extractor are on.



**WORK**  
The stove is working, in this case with working power 3. Detected room temperature is 21°C. Smokes ventilator, gear motor and room ventilator are on during this phase.



**LOAD PELLET**  
The stove starts loading pellets in the brazier.  
Resistance, smokes extractor and gear motor are on.



**CLEANING FIRE-POT**  
The stove is cleaning the brazier.  
The smokes extractor is working at its max. speed and the pellets loading is minimal.

## Menu 02 SET CLOCK

To access the set clock option, press the "SET" button (3), with the button - (5) scroll through the submenus until MENU 02 - SET CLOCK and with buttons 1 and 2 select the current day. Press the "SET" button (3) to confirm.

Then use buttons 1 and 2 to set the time and press "SET" (3) to advance to the minutes setting by pressing buttons 1 and 2. By pressing set again it's possible to access various submenus in order to set the date, day, month, and year. To do so, repeat the steps indicated above, using buttons 1, 2, and 3.

The following table briefly describes the structure of the menu, focusing only on those selections which are available to the user.

level 1	level 2	level 3	level 4	value
02 - set clock				
	01 - day			day of the week
	02 - hour			hour
	03 - minutes			minutes
	04 - day			day of the month
	05 - month			month
	06 - year			year

Set the current time and date. The device comes equipped with a lithium battery that allows the internal clock to operate autonomously for over 3-5 years.

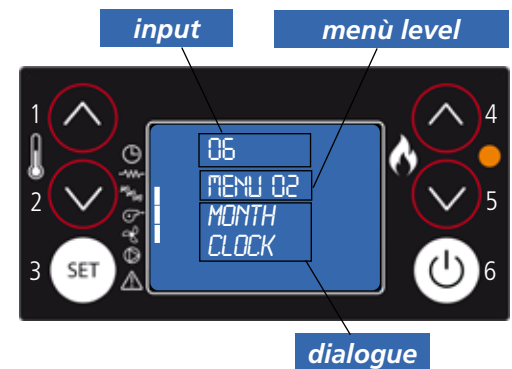

## Menu 03 SET CHRONO

Press the "SET" button (3) and then button 5 to arrive at the desired menu; press "SET" (3) to enter.

Enter menu M-3-1 and with buttons 1 and 2 select whether or not to activate the thermostat (on/off), which allows you to program the automatic ignition of the stove. Once the thermostat is activated/deactivated, press button "4" (OFF) and continue scrolling through the submenus using button 5. Select which submenu you wish to enter in order to access the daily, weekly, and weekend programmes.

To set the ignition times and days repeat the previous steps:

- access the submenu using "SET" (3)
- adjust the days, times, and activation status (on/off) with buttons 1 and 2
- confirm by pressing the "SET" button (3)
- exit from the submenu/menu with button 4 to turn it off

The following table briefly describes the structure of the menu, focusing only on those selections which are available to the user.

level 1	level 2	level 3	level 4	value
03 - set thermostat				
	01 - activate thermos.			
		01 - activate thermos.		on/off
	02 - day programme			
		01 - daily thermostat		on/off
		02 - start 1 day		hour
		03 - stop 1 day		hour
		04 - start 2 day		hour
		05 - stop 2 day		hour



level 1	level 2	level 3	level 4	value
03 - set thermostat				
	03 - week program.			
		01 - week thermostat		on/off
		02 - start program. 1		hour
		03 - stop program. 1		hour
		04 - monday progr. 1		on/off
		05 - tuesday progr. 1		on/off
		06 - wednesday prog. 1		on/off
		07 - thursday prog 1		on/off
		08 - friday prog 1		on/off
		09 - saturday prog 1		on/off
		10 - sunday prog 1		on/off
		11 - start program. 2		hour
		12 - stop program. 2		hour
		13 - monday progr. 2		on/off
		14 - tuesday progr. 2		on/off
		15 - wednesday prog. 2		on/off
		16 - thursday prog 2		on/off
		17 - friday prog 2		on/off
		18 - saturday prog 2		on/off
		19 - sunday prog 2		on/off
		20 - start program. 3		hour
		21 - stop program. 3		hour
		22 - monday progr. 3		on/off
		23 - tuesday progr. 3		on/off
		24 - wednesday prog. 3		on/off
		25 - thursday prog 3		on/off
		26 - friday prog 3		on/off
		27 - saturday prog 3		on/off
		28 - sunday prog 3		on/off
		29 - start program. 4		hour
		30 - stop program. 4		hour
		31 - monday progr. 4		on/off
		32 - tuesday progr. 4		on/off
		33 - wednesday prog. 4		on/off
		34 - thursday prog. 4		on/off
		35 - friday prog. 4		on/off
		36 - saturday prog. 4		on/off
		37 - sunday prog. 4		on/off
	04 - week-end program.			
		01 - therm. week-end		
		02 - start 1		
		03 - stop 1		
		04 - start 2		
		05 - stop 2		

## Menù 03 SET CRONO

### Submenu 03 - 01 - activate thermostat

This allows you to activate and deactivate all of the functions of the thermostat

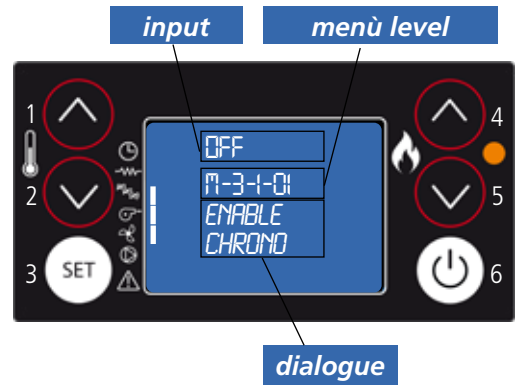

### Submenu 03 - 02 - daily programme

This allows you to enable, disable, and set the daily functions of the thermostat.

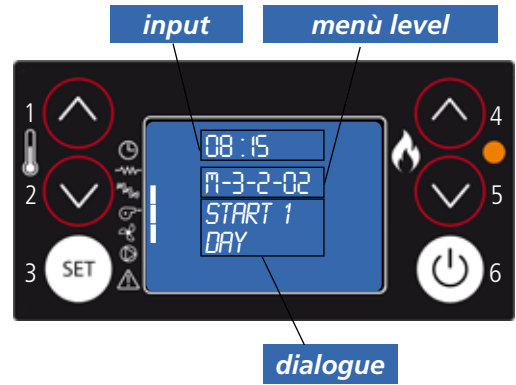

It's possible to set two operating ranges delimited by the times set according to the following table where the OFF setting tells the clock to ignore the command:

selection	meaning	possible values
START 1	activation time	hour - OFF
STOP 1	shut-off time	hour - OFF
START 2	activation time	hour- OFF
STOP 2	shut-off time	hour - OFF

### Submenu 03 - 03 - weekly programme

This allows you to enable, disable, and set the weekly functions of the thermostat.

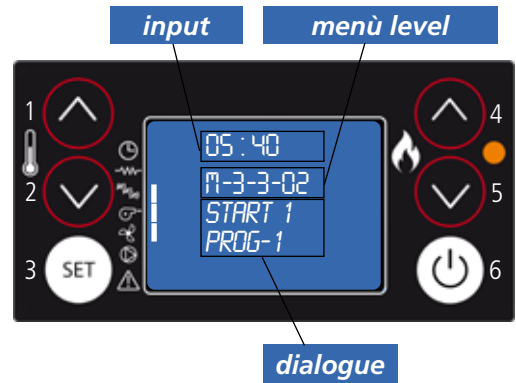

The weekly programmer has 4 independent programmes whose final effect is composed of the combination of the 4 individual programmes. The weekly programmer can be activated or deactivated. Additionally, by setting OFF in the time field, the clock ignores the corresponding command.



**Plan programming carefully in order to avoid overlapping activation/deactivation times in a single day in different programmes.**

PROGRAMME 1			
menu level	selection	meaning	possible values
02-03-02	START PROGRAM 1	activation time	time - OFF
02-03-03	STOP PROGRAM 1	shut-off time	time - OFF
02-03-04	MONDAY PROGRAM 1	reference day	on/off
02-03-05	TUESDAY PROG 1		on/off
02-03-06	WEDNESDAY PROG 1		on/off
02-03-07	THURSDAY PROGR 1		on/off
02-03-08	FRIDAY PROGRAM 1		on/off
02-03-09	SATURDAY PROGR 1		on/off
02-03-10	SUNDAY PROGR 1		on/off

PROGRAMME 2			
menu level	selection	meaning	possible values
03-03-11	START PROGRAM 2	activation time	time - OFF
03-03-12	STOP PROGRAM 2	shut-off time	time - OFF
03-03-13	MONDAY PROGRAM 2	reference day	on/off
03-03-14	TUESDAY PROG 2		on/off
03-03-15	WEDNESDAY PROG 2		on/off
03-03-16	THURSDAY PROGR 2		on/off
03-03-17	FRIDAY PROGRAM 2		on/off
03-03-18	SATURDAY PROGR 2		on/off
03-03-19	SUNDAY PROGR 2		on/off

PROGRAMME 3			
menu level	selection	meaning	possible values
03-03-20	START PROGRAM 3	activation time	time - OFF
03-03-21	STOP PROGRAM 3	shut-off time	time - OFF
03-03-22	MONDAY PROGRAM 3	reference day	on/off
03-03-23	TUESDAY PROG 3		on/off
03-03-24	WEDNESDAY PROG 3		on/off
03-03-25	THURSDAY PROGR 3		on/off
03-03-26	FRIDAY PROGRAM 3		on/off
03-03-27	SATURDAY PROGR 3		on/off
03-03-28	SUNDAY PROGR 3		on/off

PROGRAMME 4			
menu level	selection	meaning	possible values
03-03-29	START PROGRAM 4	activation time	time - OFF
03-03-30	STOP PROGRAM 4	shut-off time	time - OFF
03-03-31	MONDAY PROGRAM 4	reference day	on/off
03-03-32	TUESDAY PROG 4		on/off
03-03-33	WEDNESDAY PROG 4		on/off
03-03-34	THURSDAY PROGR 4		on/off
03-03-35	FRIDAY PROGRAM 4		on/off
03-03-36	SATURDAY PROGR 4		on/off
03-03-37	SUNDAY PROGR 4		on/off

### Submenu 03 - 04 - program week-end

This allows you to enable, disable, and set the weekend functions of the thermostat (days 5 and 6, or Saturday and Sunday).

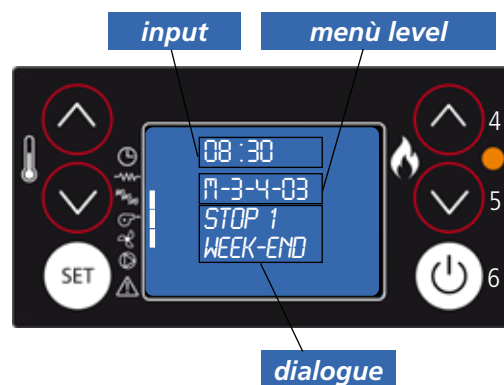

#### REMARKS:

- in order to avoid confusion and unwanted start-ups or shutdowns, activate only one programme at a time unless you know exactly what you'd like to achieve
- deactivate the daily program if you want to use the weekly program
- always leave the weekend programme deactivated if you use weekly programmes 1, 2, 3, and 4.
- activate the weekend programme only after you have deactivated the weekly programme.

### Menu 04 - select language

Press the SET button to access the menu and press  (5) up to the MENU 04 - SELECT LANGUAGE. Then press the SET button to access the menu. Select the desired language using the keys  (1) e  (2)

## Stand-by Mode

This mode allows the automatic shutdown of the stove once it reaches the temperature set on SET.

When this happens, the stove will wait a few minutes (factory setting), after which will turn off automatically if the temperature of the room in the meantime has always maintained above the set.

Once turned off as a result of this condition, the stove will automatically turn on only when the ambient temperature will drop to 2 °C below the set temperature in the oven (example: SET=24 °C and ambient temperature = 21 °C).

If the stove is turned off for the sleep-mode, although there is an ignition programmed this will be ignored and the heater will turn back on only to lower the temperature as explained above.

The sleep timer is instead always respected if the stove is in STAND-BY and is turned off manually by pressing the OFF button; doing so the stove will shut down permanently rekindling not more, less than expected from the ignition weekly programming.

### Enabling stand-by mode

Press the SET (3) to access the menu and with the button  (5) reach the *MENU 05 ("STAN-BY MODE")*. Then press SET (3) to access it; STAND-BY function is set by default to OFF.

To activate this feature, press  (1), on the display you will see "*STAN-BY MODE ON*".

Press SET (3) to confirm and then OFF (4) to leave. The STAND-BY mode is now active.

### External thermostat

The stove has the possibility to interface with an external thermostat for controlling the switching on and switching off of the heater based on the room temperature. The thermostat must be of the open / closed type with a clean contact.

If the thermostat carries voltage to the card causing faults, the warranty will expire.

To configure the thermostat, simply remove the jumper on the Therm clamp (see the tab on page 30) and connect the room thermostat.

### OPERATION BY A SPECIALIZED TECHNICIAN

Once switched on, the stove will remain in operation until the temperature set in the thermostat is reached.

When the contact is opened the stove will remain in modulation and the display will show ECO THERM for 5 minutes, after which it will go to Stand-by ECO + OFF.

At the moment of a new heat request in the room (and therefore re-closing of a contact), the stove will remain in ECO ATT mode for 10 minutes. If during this time the contact remains closed, the stove will switch on.

### NOTE:

At the moment when the stove will be switched off manually or by programming, it will no longer be connected by the thermostat.

## Alarm signals

In the event of a working defect, the system informs the user about the type of failure occurred. The following table summarises the alarms, kind of problem and possible solution:

Upper Display	Lower Display	Kind of failure	Solution
AL 5		The cannot start up This is the first light-up	Fill in the tank with pellets Start up again
AL 6	<b>NO PELLET</b>	The pellet stove switched off while working	Fill in the tank with pellets
AL 2	<b>PROBE EXHAUST</b>	The smokes sensor is broken or not connected to the pcb	Contact an Authorized Assistance Center
AL 7	<b>SAFETY THERMAL</b>	The stove is overheated	Reset the thermostat manually. If the problem persists, contact an Authorized Assistance Center.
COOL	<b>FIRE</b>	There is no power supply	As soon as the power supply is back, the stove starts a cooling cycle. After completing the cycle it starts working automatically
AL 4	<b>FAN FAILURE</b>	Smokes extractor blocked or broken	Contact an Authorized Assistance Center
AL 8	<b>FAILURE DEPRESS</b>	Obstructed flue	Clean the flue or check there are no obstructed grids near the smokes exhaust
<b>SERVICE</b>		The stove has worked for 1300 hours. Supplementary maintenance required	Contact an Authorized Assistance Center

**Regular checks should be carried out by the user, who should only contact the Authorized Assistance Center if no solution is found.**

## Vertical pipe installation Mod. 12 - 12 C

The stove is supplied with the rear smoke outlet.



In this case, a T-tube with collecting cup must be installed at the smoke outlet.



In model 12 and 12C there is the possibility to connect the vertical smoke outlet. Remove the plate that closes the vertical outlet by moving it to the rear outlet, installing the 80mm diameter nozzle you removed in the upper part of the flue box.



**It is not necessary to install the T-tube.**

## Maintenance and cleaning Mod. 12 - 12 C

Before effecting any maintenance operation or cleaning on the stove, take the following precautions:

- be sure that all parts of the stove are cold.
- be sure that the ashes are completely cold.
- be sure that the general switch is in the "OFF" position.
- be sure that the plug is pulled out of the socket to avoid accidental contact.
- once the maintenance phase is completed check that everything is in order as per before the intervention (the brazier is placed correctly).



**Follow carefully the following cleaning instructions. Failure to follow these instructions could create problems with the operation of the stove.**

### Cleaning the brazier and brazier support

When the flame assumes a red colour or seems weak, and is accompanied by black smoke, this means that there are ash deposits or incrustations that do not permit the correct functioning of the stove and that must be removed. Remove the brazier every day by simply raising it from its slot; then clean out the ashes and eventual incrustations that may have formed, paying particular attention to liberating the holes by using a pointed tool (not included with the stove). This operation is made particularly necessary before every lighting the first several times and above all if using pellets that differ from those supplied by our company. The frequency of this operation is determined by how frequently the stove is used and the choice of pellets.

It is also a good idea to check the brazier support, vacuuming the eventual ash present.

### Cleaning ash box

Open the door and extract the ash box. Use a vacuum to remove all the ash deposited within.

This operation must be performed more or less frequently depending on the quality of the pellets used.



# Maintenance and cleaning of Mod. 12 - 12 C

## CLEANING BY THE TECHNICAL

### Clean the combustion chamber and exchanger compartment

A stufa fredda e spenta procedere nel seguente modo:



Open the door and remove the brazier and the ash box.

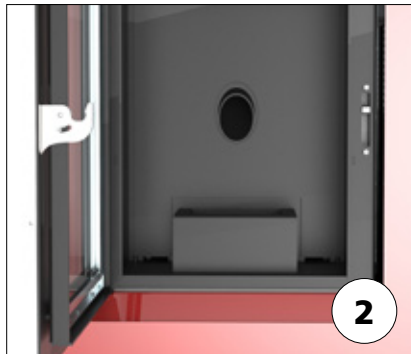

Push the back plate up.



Turn the plate towards the front of the stove.



Use a vacuum to clean the walls of the combustion chamber. Use a tool to clean the exchange pipes by removing all the combustion residues.



Once the cleaning has finished, reassemble the back plate, the ash box and the brazier.

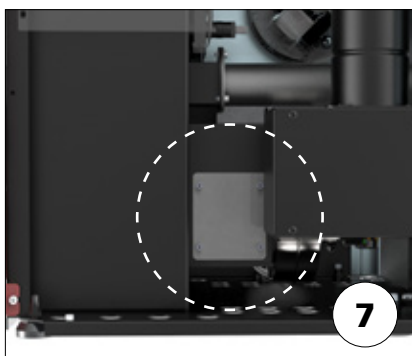
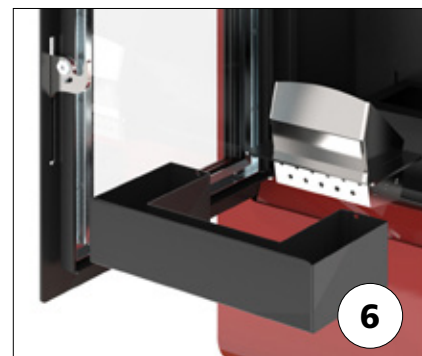

Now remove the right side of the stove and remove the closing plate.

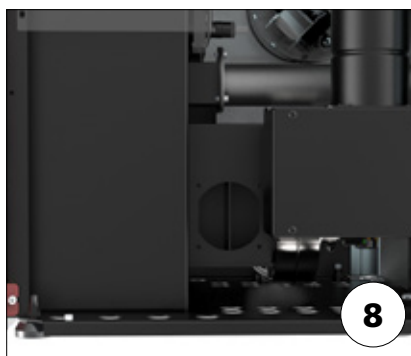

You can now access the fan compartment that must be thoroughly cleaned.



Before effecting any maintenance operation or cleaning on the stove, take the following precautions:

- be sure that all parts of the stove are cold.
- be sure that the ashes are completely cold.
- be sure that the general switch is in the "OFF" position.
- be sure that the plug is pulled out of the socket to avoid accidental contact.
- once the maintenance phase is completed check that everything is in order as per before the intervention (the brazier is placed correctly).



**Follow carefully the following cleaning instructions. Failure to follow these instructions could create problems with the operation of the stove.**

## Cleaning the brazier and brazier support

When the flame assumes a red colour or seems weak, and is accompanied by black smoke, this means that there are ash deposits or incrustations that do not permit the correct functioning of the stove and that must be removed. Remove the brazier every day by simply raising it from its slot; then clean out the ashes and eventual incrustations that may have formed, paying particular attention to liberating the holes by using a pointed tool (not included with the stove). This operation is made particularly necessary before every lighting the first several times and above all if using pellets that differ from those supplied by our company. The frequency of this operation is determined by how frequently the stove is used and the choice of pellets. It is also a good idea to check the brazier support, vacuuming the eventual ash present.

## Cleaning ash box

Open the door and extract the ash box. Use a vacuum to remove all the ash deposited within. This operation must be performed more or less frequently depending on the quality of the pellets used.

## Exchanger compartment cleaning

The exchanger compartment is located under the ash drawer; clean the latter using an aspirator.

## Cleaning the glass

The glass is a self cleaning type, therefore, while the stove is working, a veil of air is blown across its surface to remove ash and dirt; nevertheless over a period of several hours, a greyish patina tends to form which should be cleaned when the stove is next shut down. How dirty the glass becomes also depends on the quality and quantity of pellets used.

Cleaning the glass should be done when the stove is cold with products recommended and tested by our company. When performing this operation, always check that the grey seal around the glass is in a good state; failure to check the efficiency of this gasket can compromise the function of the stove.

Poor quality pellets can, in any case, cause the glass to become dirty.

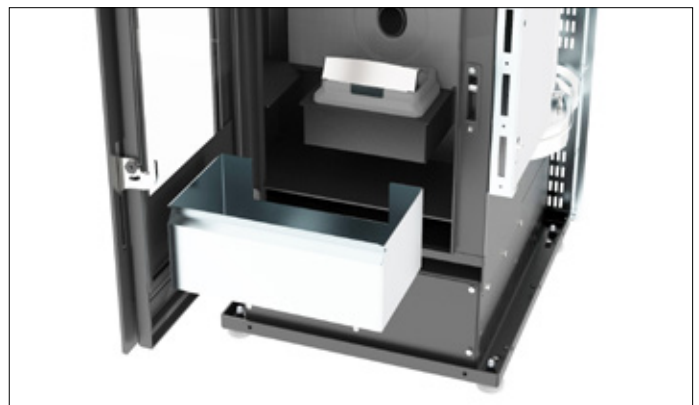
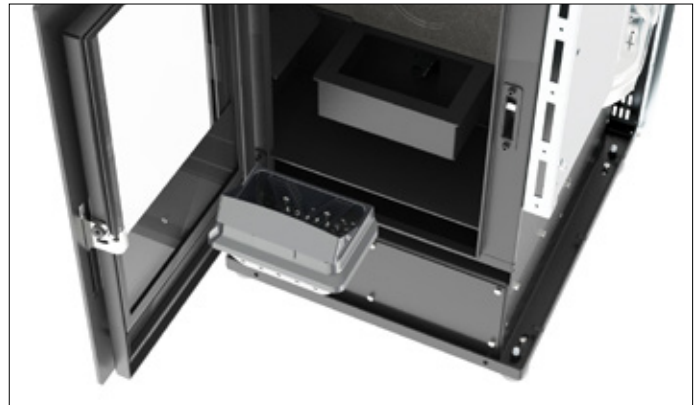



**If the glass is broken, do not attempt to light the stove.**

### Cleaning of ceramic coating (where present)

The ceramic coating must be cleaned with a soft, dry cloth. Use only neutral and delicate detergents. Do not wet and never clean the ceramic with cold water when it is hot: the thermal shock may break it.



**Be very careful because the ceramic is hot.**

### Cleaning the surfaces

To clean the surfaces, use a rag dampened with water or with water and a neutral detergent.



**The use of aggressive detergents or thinners can damage the surfaces of the stove. Before using any detergent it is advisable to try it on a small section out of sight or contact the Authorized Assistance Centre for information regarding the product.**

### Cleaning the metal parts

To clean the metal parts of the stove, use a soft cloth dampened with water.

Never clean the metal parts with alcohol, thinners, petrol, acetone or other degreasing substances. If such substances are used, our company declines any responsibility.

Eventual variations in the colour of the metal parts can be caused by an incorrect use of the stove.



**It is necessary to daily clean the brazier and often clean the ash box. The lack of cleanliness can prevent the starting of the stove, causing damages to the stove itself and to the environment (possible emission of unbrunt material and soot). Do not re-use the pellet possibly remained in the brazier due to no starting-up.**

## CLEANING BY THE TECHNICAL

### Check every year

### Clean the combustion chamber

When the stove is cold, please join the following procedure: open the door and pull the ash tray out and remove the brazier. (photo 1)

Remove the refractory fastening by pushing it upwards. (photo 2)

Turn and tilt to remove it. (photo 3)

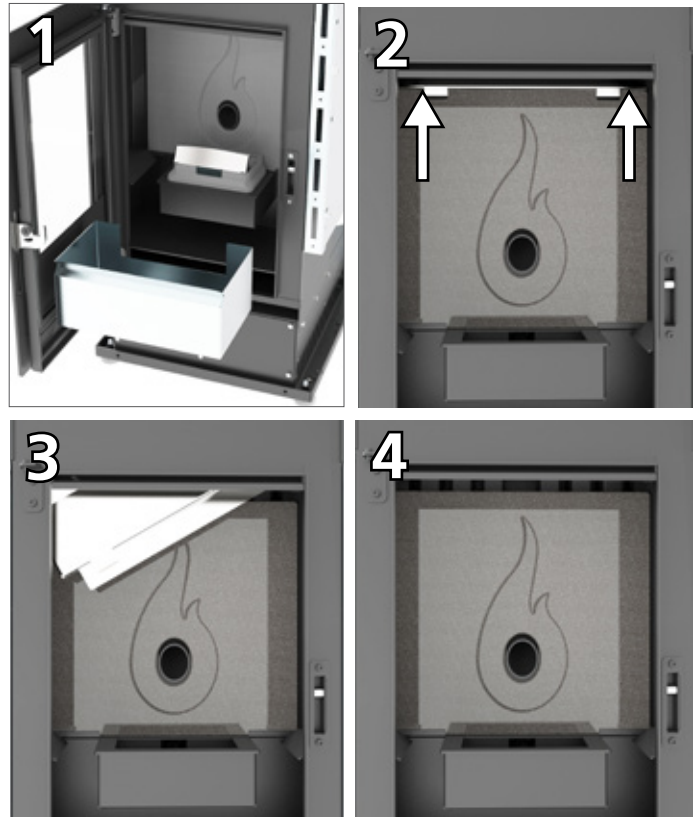

Now push the refractory upwards (photo 4 / photo 5), turn it (photo 6) and remove it from the combustion chamber.

Handle the refractory carefully, it could break because it is very fragile.

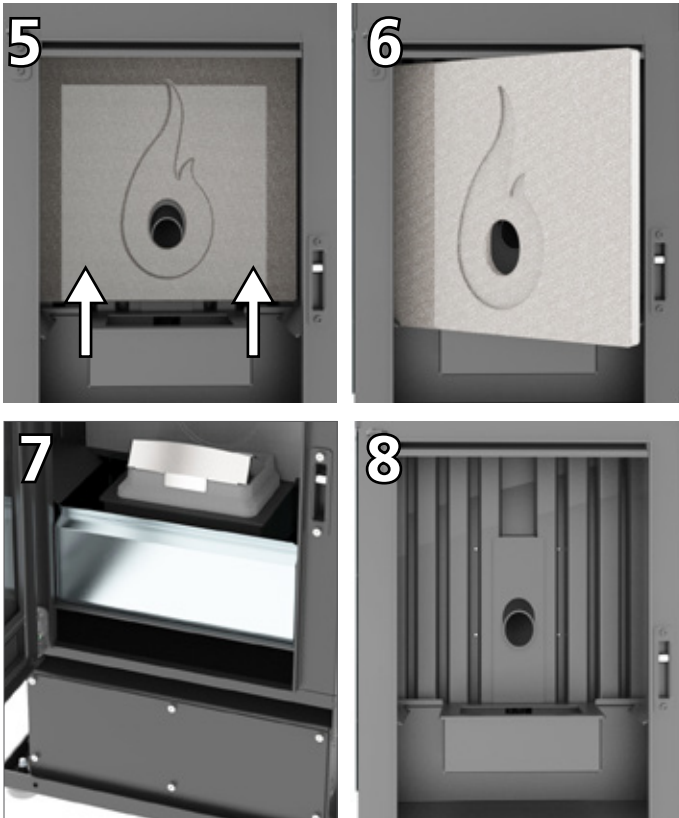

With a vacuum cleaner, clean the refractory and the walls of the combustion chamber, in particular the front wall where the heat exchanger pipes are located, (photo 9) the bottom of the combustion chamber and the compartment under the ash box. (photo 8)

Also clean the brazier and the ash drawer.

Once the cleaning has been completed, reassemble the refractory, the relative fixing, the ash drawer and finally the brazier.

### Cleaning the clearing system

Until a reasonable experience is acquired regarding the operating conditions, it is advisable to perform this maintenance on at least a monthly basis.

- remove the electrical feed cable;
- remove the cap from the T-joint and proceed with the cleaning of the ducts. If necessary, at least for the first few times, call in qualified personnel;
- carefully clean the smoke discharge system: for this, contact a professional chimney sweep;
- once a year clean the dust, cobwebs, etc. from the zone behind the internal covering panels, paying particular attention to the fans.

### Cleaning the fans

The stove is furnished with fans (environmental and smoke) positioned at the rear and below the stove.

Eventual deposits of dust or ash on the blades of the fan can cause an imbalance in the fans leading to noisy performance. It is, therefore, necessary to clean the fans at least once a year.

Since said operation requires dismantling several parts of the stove, have the fans cleaned only by our Technical Assistance Centre.

### Season end cleaning

At the end of the season, when the stove will not be used for some time, it is advisable to perform a thorough and general cleaning:

- Remove all the pellets from the container and the screw feeder;
- Carefully clean the brazier, the brazier support, the combustion chamber and the ash box.

Once the preceding points have been observed, it only means that the state of the stove has been verified.

It is necessary to thoroughly clean the smoke discharge tube or flue and check the condition of the basket. If necessary, order a new one from our Authorized Assistance Centre.

If necessary, lubricate the hinges of the door and the handle. Also check the ceramic fibre cord near the glass, on the internal wall of the door; if it is worn or too dry, order a new one from the Authorized Assistance Centre.

## Maintenance and cleaning



All cleaning of all parts must be carried out with the stove completely cold and unplugged to avoid burns and thermal shock. The stove does not need much maintenance if used with certified quality pellet. The need for maintenance varies depending on the conditions of use (switching on and off repeatedly) and depending on the performance required.

Parts	Everyday	Every 2-3 days	Every week	Every 15 days	Every 30 days	Every 60-90 days	Every year / 1200-1400 h
Brazier	◇						
Cleaning ash collection compartment		◇					
Cleaning ash tray		◇					
Cleaning the door and glass		◇					
Cleaning the interior heat exchanger / smoke fan compartment						•	
Cleaning complete exchanger							•
Clean "T" to exhaust						•	
Flue							•
Door gasket ash						•	
Internal parts							•
Flue pipe							•
Electromechanical components							•

◇ by the user

• by the authorised qualified technical assistance



Every 1300 hours of work the electronic board sends a warning signal and the display will show "SERVICE". This indicates the need for a thorough cleaning of the stove by a CAT. The lack of such cleaning could result in failure of the stove and poor combustion, thereby resulting in a lower yield.

## Safety devices



**Pressure switch:** monitors depression in the smoke duct. It is designed to shut down the pellet feed screw in the event of an obstructed flue or significant back-pressure in the presence of wind. At the time of the pressure switch will show **"ALAR-DEP-FAIL"**.

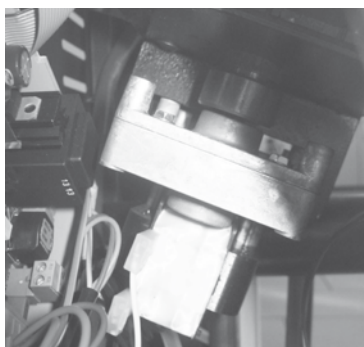

**Reduction motor:** if the motor stops, the stove continues to function until the flame goes out for lack of fuel, and until it has cooled down to the minimum level.

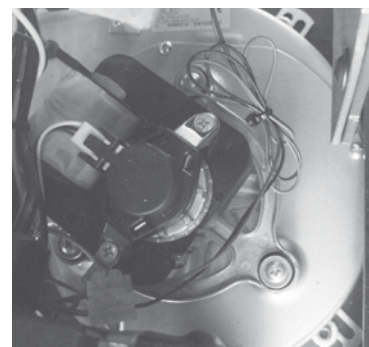

**Flue gas temperature sensor:** thermocouple that measures the temperature of the fumes while keeping the operation or shuts the stove when the flue gas temperature drops below the preset value.



**Electrical safety:** the stove is protected against violent surges of current (ex. lightnings) by the main fuse 4 A which is located on the control panel at the rear of the stove. Other fuses to protect the electronic boards are to be found on the boards themselves.



**Pellets temperature safety:** In the rare event there is a too high temperature in the tank, the thermostat for pellets safety with manual reset creates an alarm **"ALAR-SIC-FAIL"** stopping the pellet boiler stove. You need to reset the system working on the device placed on the back of the stove.



**Room thermostat:** the room thermostat detects the present temperature in the room. When it detects the set temperature on the display, the stove will go into operation in ECO ie hold function to save fuel. The room thermostat should be spread so as not to be conditioned by the temperature of the body stove.



***Tampering with the safety devices is prohibited.*** It is only after eliminating the cause which gave rise to the intervention of the safety system, that it is possible to relight the stove and thus reset the automatic operation of the sensor. To understand which anomaly has occurred, consult this manual at paragraph relating to alarms which explains what to do based on the alarm message the stove display.

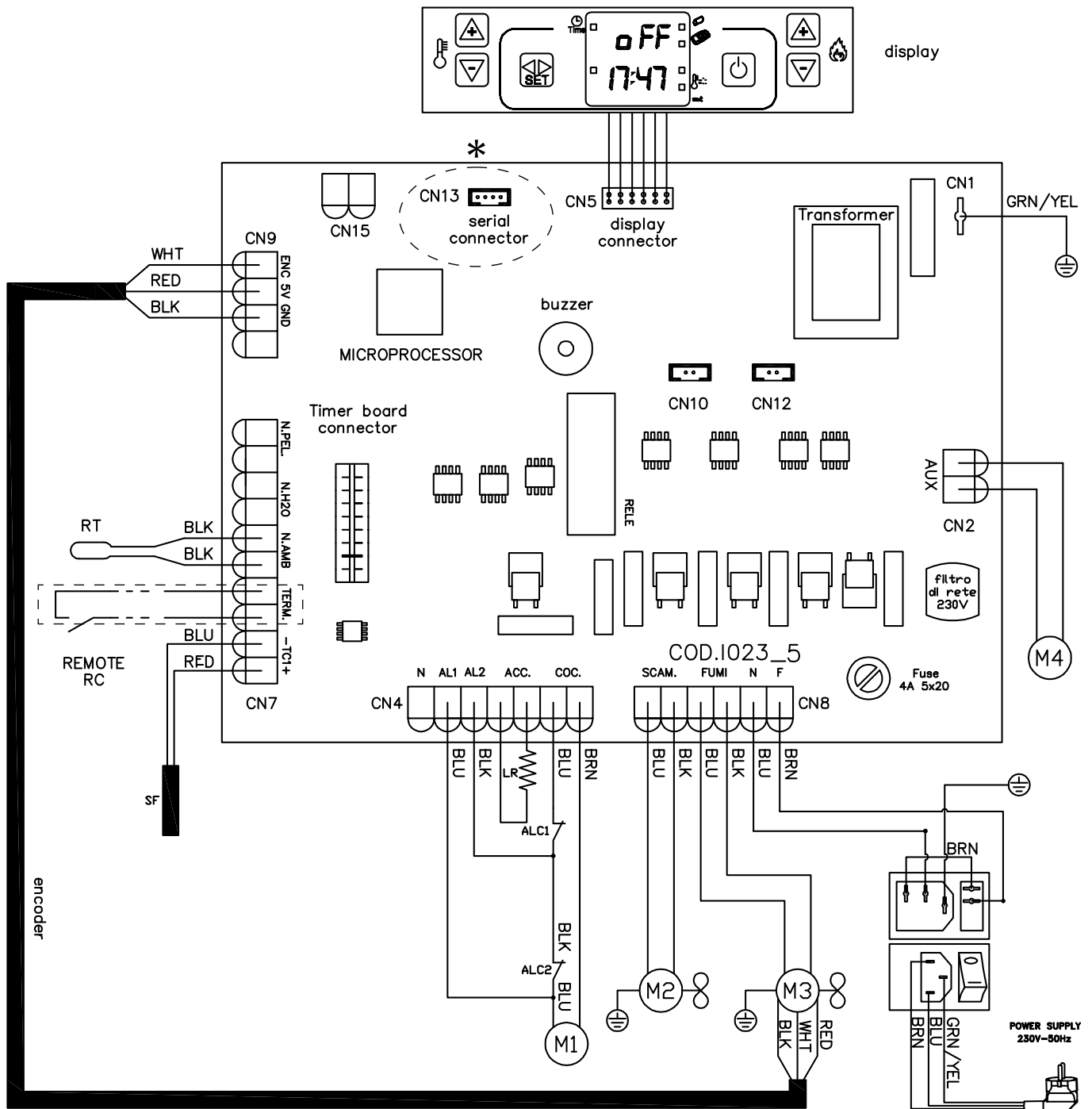

ENG

M1	coclea mothor
M2	ambient fan motor
M3	smoke extractor
M4	second ambient fan (where present)
ALC1	pellet tank thermostat
ALC2	pressure switch
*	Wi-Fi module connector

ITA

M1	coclea
M2	motore ambiente
M3	estrattore fumi
M4	secondo ventilatore (dove presente)
ALC1	termostato
ALC2	pressostato
*	connettore modulo Wi-fi



## Problems and solutions



**All repairs must be carried out exclusively by a specialised technician, with the stove completely cold and the electric plug pulled out. Is prohibited from any unauthorized modification to the device and the replacement of parts with other non-original. The operations marked in bold type must be carried out by specialised personnel.**

### Any inconvenience and solutions

Given that all stoves are tested in their parts handling and work and therefore are delivered in perfect physical condition and operation, it should be remembered that the transport, unloading, handling, misuse or poor maintenance, can be causes of drawbacks.

The main problems may be solved by reading the table below.

If after doing as hereinafter described the problem is not resolved, contact your authorized service center.

PROBLEM	POSSIBLE CAUSE	REMEDY
Display off and buttons are not working	<ol style="list-style-type: none"> <li>1. Power failure in the network</li> <li>2. Switch back off</li> <li>3. Display defective</li> <li>4. Fault in the connection of the display with the card</li> <li>5. Fuse board interrupted</li> <li>6. Card defective</li> </ol>	<ol style="list-style-type: none"> <li>1. Check that the power cord is connected</li> <li>2. Use the switch back to operate it</li> <li>3. Unplug the stove from the power outlet for about one minute and then turn on. If the problem persists, contact an authorized service center</li> <li><b>4. Check that the display and board are properly connected. Contact your authorized service center</b></li> <li><b>5. Contact an authorized service center</b></li> <li><b>6. Contact an authorized service center</b></li> </ol>
Remote inefficient	<ol style="list-style-type: none"> <li>1. Too far from the stove</li> <li>2. No batteries in the remote</li> <li>3. The remote control is broken</li> </ol>	<ol style="list-style-type: none"> <li>1. Move closer to the stove</li> <li>2. Check and change the batteries</li> <li>3. Replace the remote control</li> </ol>
Failure to ignite the stove	<ol style="list-style-type: none"> <li>1. Excessive accumulation of ash in the grate</li> <li>2. Incorrect ignition procedure</li> </ol>	<ol style="list-style-type: none"> <li>1. Clean the grate</li> <li>2. Repeat the ignition procedure. <b>If the problem persists, contact your authorized service center</b></li> </ol>
Smoke comes from the grill	<ol style="list-style-type: none"> <li>1. Accidental electrical blackout</li> </ol>	<ol style="list-style-type: none"> <li>1. In case of ignition phase interrupted and momentary interruption of the fan, can occur slight amount of smoke</li> </ol>
Hot air fan is not working	<ol style="list-style-type: none"> <li>1. The stove has not yet been heated</li> </ol>	<ol style="list-style-type: none"> <li>1. Wait until the conclusion of the ignition cycle. Arrived in temperature, the fan will start automatically. If the problem persists, contact your authorized service center.</li> </ol>

<p>The stove does not turn on automatically</p>	<ol style="list-style-type: none"> <li>1. The tank is empty.</li> <li>2. The resistance does not reach the temperature</li> <li>3. Resistance damaged</li> <li>4. The pellet drops</li> <li>5. Screw motor defective</li> <li>6. The grate is not in place or is dirty</li> <li>7. Obstruction of nests or foreign bodies in the chimney or fireplace</li> <li>8. Check operation of the glow plug</li> <li>9. The ash drawer is not closed properly</li> <li>10. Clogged flue and chimney</li> <li>11. Smoke extractor not working</li> <li>12. Temperature sensor defective</li> <li>13. Pellet wet</li> </ol>	<ol style="list-style-type: none"> <li>1. Fill the tank with pellets</li> <li>2. Check the electrical wiring and fuses, replace if the resistance is broken</li> <li>3. Replace the resistance</li> <li>4. It is recommended to unplug the power supply before: <ul style="list-style-type: none"> <li>- check that the pellet is not caught in the chute</li> <li>- check that the cochlea is not blocked by dirt</li> <li>- check the seal of the pellet-door</li> </ul> </li> <li><b>5. Contact an authorized service center</b></li> <li>6. Check that the hole in the brazier matches the glow plug, clean brazier</li> <li>7. Remove any foreign body from the chimney or flue pipe</li> <li>8. Make sure that there is power. Replace the spark plug if burned</li> <li>9. Close the drawer ashtray</li> <li>10. Perform periodic cleaning</li> <li><b>11. Check the operation of the extractor flue</b></li> <li><b>12. Contact an authorized service center</b></li> <li>13. Make sure the place of stowage pellet and replace it with a handful of dry pellets</li> </ol>
<p>Lock the stove. Pellets not being fed into the combustion chamber</p>	<ol style="list-style-type: none"> <li>1. The tank is empty</li> <li>2. The cochlea is no pellet</li> <li>3. Technical problem of the cochlea</li> <li>4. Reduction motor failure</li> <li>5. Electronic board faulty</li> </ol>	<ol style="list-style-type: none"> <li>1. Load the pellets in the tank.</li> <li>2. Fill the tank and proceed as instructed before ignition stove</li> <li>3. IT IS RECOMMENDED to unplug the power supply before: <ul style="list-style-type: none"> <li>- empty the tank and manually free the auger from obstructions (sawdust)</li> <li>- release the slide from obstructions</li> <li>- remove the dust accumulation of pellets in the bottom of the tank</li> </ul> </li> <li><b>4. Replace the reduction motor</b></li> <li><b>5. Replace the electronic board</b></li> </ol>
<p>The stove runs for a few minutes and then turn off</p>	<ol style="list-style-type: none"> <li>1. Lighting cycle not completed</li> <li>2. Temporary failure of electricity</li> <li>3. Probes fumes defective or broken or not inserted</li> </ol>	<ol style="list-style-type: none"> <li>1. Re-run power</li> <li>2. Re-run power</li> <li><b>3. Check and replace sensors</b></li> </ol>
<p>Fume extraction fan does not stop</p>	<ol style="list-style-type: none"> <li>1. The stove has not yet cooled</li> </ol>	<ol style="list-style-type: none"> <li>1. Allow the stove to cool. Only after cooling fan will stop. <b>If the problem persists, contact your authorized service center</b></li> </ol>



<p>The stove is clogged early in the brazier with burning irregular, door glass gets dirty, the flame is long, reddish and weak</p>	<ol style="list-style-type: none"> <li>1. Flue with presence of stretches too long or clogged</li> <li>2. Too pellet</li> <li>3. Excessive pellet or ash deposits in the brazier</li> <li>4. The brazier is not found in its slot</li> <li>5. Wind contrary to the exhaust flow</li> <li>6. Insufficient combustion air</li> <li>7. You changed the type of pellets used</li> <li>8. Smoke extractor motor broken</li> <li>9. Door closed incorrectly</li> </ol>	<ol style="list-style-type: none"> <li>1. Perform periodic cleaning. See paragraph stove installation in the user manual. Check chimney cleaning</li> <li>2. Decrease in the parameters the charge level of the pellets</li> <li>3. Clean the brazier after waiting for the total shut-down of the stove. <b>If you repeat contact your Authorized Service Center</b></li> <li>4. Check that the hole in the brazier matches the glow plug</li> <li>5. Check the chimney cap windproof and / or possibly install it</li> <li>6. Check the correct position of the brazier, its cleanliness and check that the air intake in both free environment, verify the status of the door seal, increase the level in the parameter relative to the speed of the fan exhaust fumes. <b>Contact your Authorized Service Center</b></li> <li>7. Check the quality of the pellets. <b>Contact your Authorized Service Center</b></li> <li>8. Increase the level in the parameters relating to the speed of the fan exhaust fumes. <b>Check and eventually replace motor</b></li> <li>9. Check that the glass is sealed and the seal guarantees tightness</li> </ol>
<p>Smell of smoke in the environment. Turning off the stove.</p>	<ol style="list-style-type: none"> <li>1. Poor combustion</li> <li>2. Malfunction of fan fumes</li> <li>3. Installation of the flue performed incorrectly</li> <li>4. Clogged chimney</li> </ol>	<ol style="list-style-type: none"> <li><b>1. Contact your Authorized Service Center</b></li> <li><b>2. Contact your Authorized Service Center</b></li> <li><b>3. Contact your Authorized Service Center</b></li> <li><b>4. Contact your Authorized Service Center</b></li> </ol>
<p>In the automatic position the stove always runs at full power</p>	<ol style="list-style-type: none"> <li>1. Room thermostat set to maximum</li> <li>2. Significant temperature sensor failure</li> <li>3. Control panel defective or broken</li> </ol>	<ol style="list-style-type: none"> <li>1. Reset the thermostat temperature</li> <li>2. Check the operation of the sensor and replace if necessary</li> <li>3. Check the control panel and replace if necessary</li> </ol>
<p>The engine smoke extraction does not work</p>	<ol style="list-style-type: none"> <li>1. The stove has no voltage</li> <li>2. The motor is broken</li> <li>3. The board is defective</li> <li>4. The control panel has failed</li> </ol>	<ol style="list-style-type: none"> <li>1. Check the supply voltage and the protection fuse.</li> <li>2. Check the motor and capacitor and replace if necessary.</li> <li>3. Replace the circuit board.</li> <li>4. Replace the control panel.</li> </ol>

<p>The fire goes out or the stove stops automatically</p>	<ol style="list-style-type: none"> <li>1. The pellet tank is empty</li> <li>2. No power</li> <li>3. Pellets not being fed</li> <li>4. Excessive deposit of ashes in the grate</li> <li>5. Intervention probe temperature safety of the pellet</li> <li>6. Cochlea blocked by dirt</li> <li>7. The door is not closed properly or gaskets worn</li> <li>8. Pellet inadequate</li> <li>9. Low pellet</li> <li>10. Chimney or drain clogged with nests or foreign bodies</li> <li>11. Pressure switch cuts</li> <li>12. Smoke extraction motor failure</li> <li>13. Alarm active</li> </ol>	<ol style="list-style-type: none"> <li>1. Fill the tank with pellets</li> <li>2. Check plug and presence electricity</li> <li>3. Fill the tank with pellets</li> <li>4. Clean the brazier</li> <li>5. Let the stove cool down completely, reset the manual reset and restart the stove. If the problem persists, contact your authorized service representative</li> <li>6. Pull the plug, empty the tank, remove any foreign objects</li> <li>7. Close the door or replace the gaskets with original</li> <li>8. Change the type of pellet recommended by the manufacturer. <b>Sometimes, depending on the type, the stage of adjustment of the parameters need to vary the level relating to the loading of pellets</b></li> <li>9. Increase the level in the parameter for the pellet feed. <b>To check the flow of fuel from technical authorized</b></li> <li>10. Eliminate all foreign matter from the chimney Clean the smoke duct. Perform periodic cleaning.</li> <li><b>11. Verify potential smoke duct is blocked and if the pressure switch is working properly</b></li> <li><b>12. Check and replace the motor if necessary</b></li> <li>13. See paragraph alarms</li> </ol>
<p>The air fan convention (ambient air) never stops</p>	<ol style="list-style-type: none"> <li>1. Temperature sensor temperature control defective or broken</li> <li>2. Smoke probe fails</li> </ol>	<ol style="list-style-type: none"> <li>1. Check the operation of the sensor and replace if necessary</li> <li>2. Replace smoke probe</li> </ol>
<p>The stove does not light.</p>	<ol style="list-style-type: none"> <li>1. Lack of electricity</li> <li>2. Probe pellets in bulk</li> <li>3. Fuse blown</li> <li>4. Pressure switch broken (lockout indicated)</li> <li>5. Smoke outlet or duct clogged</li> </ol>	<ol style="list-style-type: none"> <li>1. Check that the electrical outlet is plugged in and the power switch to "I"</li> <li>2. Lockout by resetting the rear thermostat, <b>replace the thermostat</b> if it happens again</li> <li>3. Replace the fuse</li> <li><b>4. Replace the pressure</b></li> <li>5. Clean the smoke outlet and / or smoke duct</li> </ol>



**Never turn off the heater by removing electricity.**

**Let always complete the shutdown cycle, otherwise you may damage the structure and have trouble lighting in the future.**



**The manufacturer of the stove any liability and will void the warranty terms of the product for any inconvenience caused by not following the rules described above. Any work of service center will be borne by the applicant if they are not complied with these instructions.**

## GENERAL GUARANTEE

All products are subject to accurate testing and are covered by warranty for 24 months from the date of purchase, documented by invoice or purchase receipt that will be presented to authorized technicians. If the document does not show up, it will be invalidate the right of the owner of the appliance. Warranty means the replacement or repair of parts of the appliance that are defective at source due to manufacturing faults.

1. Warranty covering manufacturing defects and defects in material declines:

- for unauthorized personnel work;
- for damage caused by transport or for causes not attributable to the manufacturer;
- for incorrect installation;
- for incorrect electrical connection;
- for periodic maintenance not performed;
- for outdoor accidents (lightning, floods, etc ...);
- for incorrect use and maintenance.

2. Complete replacement of the machine can only take place following the unquestionable decision by the manufacturer in special cases

3. The Company declares no responsibility for any damage that may, directly or indirectly, result in persons, things or animals as a result of non-observance of the instructions in the Instructions book and in particular concerning the installation, use and maintenance of the appliance.

## GUARANTEE LIMITATIONS

Limited Warranty covers manufacturing defects, provided that the product has not been damaged by improper use, improper handling, incorrect connection, tampering, and installation errors. The following components are covered by a twelve months warranty:

- combustion burners;
- resistance.

They are not covered by warranty:

- the glass of the door;
- general gasket and fiber door;
- painting;
- tiles;
- the remote control
- Internal sides
- Any damage caused by inadequate installation and / or shortages of the consumer.

The images are purely indicative and may not match the reality of the product. Pictures are only exemplary and they are needed to understand how the product works.

