

Dear Customer,

We thank you for having chosen one of our products, the fruit of technological experience and of continual research for a superior quality product in terms of safety, dependability, and service. In this manual you will find all the information and useful suggestions to use your product with the maximum safety and efficiency.



We highly recommend to turn to our Authorized Service Centre for the installation and the first ignition of the device as it not only carries out the installation perfectly but also verifies the regular operation of it.

- Incorrect installation, incorrectly performed maintenance, improper use of the product release the manufacturer from every eventual damage derived from the use of the stove.
- The unit cannot be used as an incinerator. Do not use fuels other than pellets.
- This manual has been realized by the manufacturer and constitutes an integral part of the product and must remain with it during its entire lifetime. If the product is sold or transferred, be sure that the booklet is present since the information contained in it are addressed to the buyer, and to all those persons of various titles who complete the installation, use and maintenance.
- Carefully read the instructions and the technical information contained in this manual, before proceeding with the installation, use, and any operation on the product.
- The observance of the indications contained in the present manual guarantees the safety of people and the product, the economy of use and a longer functioning lifetime.
- Although the carefully studied design and the risk analysis done by our company has permitted the realization of a safe product, in any case, before effecting any operation on the stove, it is recommended to keep said manual available and pay scrupulous attention to the instructions written therein.
- Be very careful when moving the ceramic details where present.
- Check the precise flatness of the pavement where the product will be installed
- The wall where the product will be placed must not be constructed in wood, or in any case, made of an inflammable material, and in addition it is necessary to maintain a safety distance.
- While the stove is in operation, several parts of the stove (door, handle, sides) can reach high temperatures. Therefore pay attention and use the proper precautions, above all in the presence of children, elderly or disabled persons, and animals.
- Assembly must be performed by authorized persons (Authorized Assistance Center).
- Diagrams and drawings are furnished for the purpose of illustration; the manufacturer, with the intent of pursuing a policy of constant development and renewal of the product can, without any notice, make any modifications that are believed opportune.
- When the stove is working at its maximum speed, it is strongly suggested to wear gloves while handling with the door for pellets loading and the door handle.
- It is prohibited to install in bedrooms or in explosive environments.
- Only use replacement parts recommended by the supplier.



Never cover the body of the stove in any way or obstruct the openings placed on the upper side when the device is operating. All our stoves are trial lighted on the construction line.

In the event of a fire, disconnect the power supply, use an extinguisher and call the fire fighters if necessary. After that contact the Authorized Assistance Center.

This instruction booklet is an integral part of the product: make sure that it always accompanies the appliance, even in case of transfer to another owner or in the case of transfer to another place. In the event of damage or loss, request a copy from the area technician.

These symbols indicate specific messages in this booklet:

**ATTENTION:**

This warning sign indicates that the message to which it refers should be carefully read and understood, **because failure to comply with what these notices say can cause serious damage to the stove and put the user's safety at risk.**

**INFORMATION:**

This symbol is used to highlight information which is important for proper stove operation. Failure to comply with these provision will compromise use of the stove and its operation will not be satisfactory.

Norms and declarations of conformity

Our company declares that the stove conforms to the following norms for the EC European Directive labelling:

- 2014/30 UE (regulation EMCD) and following amendments;
- 2014/35UE(LowVoltageDirective)andfollowing amendments;
- 2011/65 EU (RoHS 2 directive);
- 2015/863 EU (delegated directive recently amended Annex II of the Directive 2011/65 EU);
- Ecodesign directive 2009/125/EC;
- The Rules of Construction Products (CPR-Construction Products Regulation) No. 305/2011 regarding the construction world;
- For installations in Italy, please refer to UNI 10683/98 or following changes. **While installing the unit respect the local, national and European rules;**
- EN 55014-1; EN 55014-2; EN 61000-3-2; EN 61000-3-3; EN 60335-1; EN 60335-2-102; EN 62233, EN 50581. Regulation EU 2015/1185.

Safety information

Please carefully read this use and maintenance manual before installing and operating the stove! If clarification is needed, please contact the dealer or the Authorized Assistance Center.

- The pellet stove must only be operated in living environments. This stove, being controlled by an electronic board, permits a completely automatic and controlled combustion; the exchange, in fact, regulates the lighting phase, 5 power levels and the shut down stage, guaranteeing the safe operation of the stove.
- The basket used for combustion allows most of the ash produced by the combustion of the pellets to fall into the collection compartment.

Nevertheless, check the basket daily, given that not all pellets have high quality standards (use only quality pellets recommended by the manufacturer)

Responsibility

With the delivery of the present manual, we decline all responsibility, both civil and penal, for accidents deriving from the partial or total lack of observance of the instructions contained herein.

We decline every responsibility derived from improper use of the stove, from incorrect use by the user, from unauthorized modifications and/or repairs, from the use of replacement parts that are not original for this model. The manufacturer declines every civil or penal, direct or indirect responsibility due to:

- Lack of maintenance;
- Failure to observe the instructions contained in the manual;
- Use in non-conformity with the safety directives;
- Installation in non-conformity with the norms in force in the country;
- Installation by unqualified or untrained personnel;
- Modifications and repairs not authorized by the manufacturer;
- Use of non-original replacement parts;
- Exceptional events.

Charge pellet

Fuel is loaded from the upper part of the stove by opening a door.

Pour the pellets in the hopper. This is easier if performed in two steps:

- Pour half of the contents of the bag into the hopper and wait for the fuel to settle on the bottom.
- Then pour in the second half;
- Keep the cover closed, after loading the pellets, the lid of the fuel tank;
- Before closing the door load-pellet make sure that there are no residues of pellets around the seal. If carefully cleaned to avoid compromising the seals.

The stove is a product by heating, presents the external surfaces particularly hot.

For this reason, we recommend extreme caution when operating in particular:

- Do not touch the stove body and the various components, do not approach the door, it could cause burns;
- Do not touch the exhaust fumes;
- Do not perform any type of cleaning;

- Do not dump the ashes;
- Do not open the ash tray;
- Be careful that children do not come near;



Never remove the protection grille in the hopper. When filling, do not let the sack of pellets touch any hot surfaces.



- **Use only wood pellets;**
- **Keep / store the pellets in a cool dry place;**
- **Never pour pellets directly on the hearth;**
- **The stove must only be fed with quality 6 mm diameter pellets, A1 certified according to the UNI EN ISO 17225-2 regulations;**
- **Before making the electrical connection of the stove the discharge tubes must be connected with the flue;**
- **The protective grill placed inside the pellet container must never be removed;**
- **The environment where the stove is installed must have a sufficient exchange of air;**
- **It is forbidden to operate the stove with the door open or the glass broken;**
- **Do not use the stove as an incinerator; the stove should be used only for the intended purpose;**
- **Any other use is considered improper and therefore dangerous. Do not put in the hopper other than wood pellets;**
- **When the stove is operating, the surfaces, glass, handle and tubes become very hot: during operation do not touch these parts without adequate protection;**
- **Keep the fuel and other inflammable materials off the stove.**



Never turn off the heater by removing electricity. Let always complete the shutdown cycle, otherwise you may damage the structure and have trouble lighting in the future.

Instructions for safe and efficient use

- The device can be used by children that are not less than 8 years old and people with reduced physical, sensory or mental capabilities, or lack of experience or knowledge, provided being under supervision of someone responsible or after having received instructions relating to the safe use of the device and to the understanding of the dangers inherent to it. Children should not play with the device. Cleaning and maintenance to be performed by the user should not be made by children without supervision;
- Do not use the stove as a ladder or scaffold;
- Do not put clothes to dry on the stove;
- Any clothes hangers and suchlike must be kept a suitable distance from the stove. - Risk of fire;
- Carefully explain that the stove is made from material subjected to high temperatures for the elderly, the disabled, and in particular for all children, keeping them away from the stove during operation;
- Do not touch the stove with wet hands: the stove has electrical components that could produce sparks if handled incorrectly;
- Never open the glass door of the pellet stove while the stove is in operation;
- The stove must be connected to an electrical system equipped with an earthing conductor in accordance with regulations 73/23 and 93/98 EEC;
- The system must be of adequate electrical power declared the stove;
- Do not wash the inside of the stove with water.
- The water could damage the electrical insulation, causing electric shock;
- Do not expose your body to hot air for a long time. Do not overheat the room you are in and where the stove is installed. This can damage the physical conditions and cause health problems;
- Do not expose to direct the flow of hot air plants or animals;
- The pellet stove is not a cooking element;
- External surfaces during operation can become very hot. Do not touch them except with the appropriate protection;
- The plug of the device power cable must be connected only after installation and assembly of the device and must remain accessible after installation, if the unit is not provided of a double-pole switch suitable and accessible.
- Pay attention that the power cord (and any other cables external to the appliance) do not touch hot parts.
- Do not lay objects, glasses, infusers, room perfumers on the stove, they could be damaged or to damage the stove (in this case de warranty does not respond).
- In the event of a start-up system, do not force switch on;
- Unburnt pellet accumulation in the burner following "no switch on" must be removed before proceeding with new switch on. Before each restart, ensure the grate is well positioned and clean;
- It is forbidden to manually load the fuel in the grate. Non-compliance with this warning can generate dangerous situations;
- Evaluate the static conditions of the surface on which the weight of the product gravitates;
- Extraordinary maintenance operations must be carried out by authorised and qualified staff only;
- Disconnect the electrical power supply of the product before carrying out any maintenance operation;
- On first start-up, smoke may generate due to initial heating of the paint. Keep the premises well ventilated.



The stove is equipped with a safety device to prevent operation with dangerous negative pressure in the combustion chamber caused for example by unfavourable climatic situations or blockages in the flue. If intervening on this device, do not tamper with it and wait for the climatic situation to allow the flue to return to a negative pressure that would guarantee correct operation of the stove. If the stove is installed in particularly windy situations for long periods of time which would prevent daily use of the stove, the smoke extractor speed can be increased to guarantee correct negative pressure in the combustion chamber.

For proper functioning and a good temperature distribution, the stove should be positioned in a location where it is able to take in the air necessary for combustion of the pellet (about 40 m³/h must be available), as laid down in the standard governing the installation and in accordance with local national standards. The volume of the room must not be less than 20 m³. It is compulsory to install an adequate outdoor air intake which would allow oxidising air input necessary for correct operation of the product. The air flow between the outside and the installation premises can take place directly, through an opening on an external wall of the premises (preferred solution, see Figure 1a); or indirectly, through air intake from the adjoining premises with air intake and permanently communicating with the installation premises (see Figure 1b). Adjoining premises excludes those used as bedrooms, bathrooms, garages, common areas of a building and, in general, premises in danger of catching fire. Consider the doors and windows present which could interfere with correct air flow to the stove and maintain 1.5 metres from any smoke outlet. The air intake must have a minimum total net surface of 100 cm² protected by an external grate which must not be obstructed and/or blocked and which should be periodically cleaned: the aforementioned surface should be increased as a result if there are other active generators inside the premises (for example: electric fans for stale air extraction, kitchen hood, other stoves, etc...), which could generate a negative pressure environment. A check is necessary, with all the equipment on, that the drop in pressure between the room and the outdoors does not exceed a value of 4 Pa.

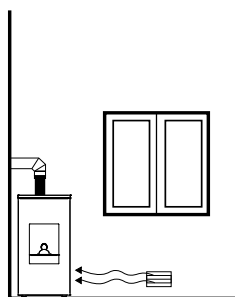

FIGURE 1a- DIRECTLY FROM OUTSIDE

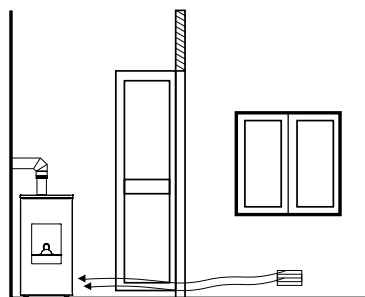
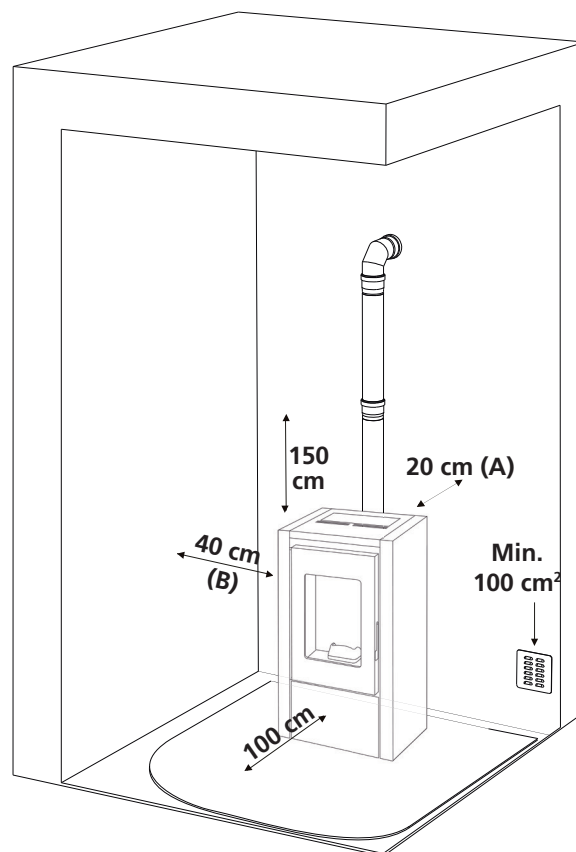

FIGURE 1b- INDIRECTLY FROM ADJACENT PREMISES

You can connect the air necessary for combustion directly to the external air intake, with a tube of at least 40mm, with a maximum length of 2 linear metres; each curve of the tube is equal to a loss of one linear metre.



Installation in studio flats, bedrooms and bathrooms is only permitted for airtight or closed chamber equipment with an adequate canalization for oxidising air duct outwards.



Locating the stove in a room with an explosive atmosphere is prohibited. The floor of the room where the stove is to be installed must be strong enough to take its weight. Keep a minimum rear distance (A) of 20 cm, on the side (B) 40 cm and, on the front, 100 cm. These distances must be complied with to allow extraordinary maintenance by a technician and product safety. If particularly delicate objects are present such as furniture, curtains or sofas, the distance of the stove must be increased considerably



In the presence of wood floors, install a floor protection surface in compliance with the rules in force in the country

REMARKS:

- the appliance must be installed by a qualified technician in possession of the technical and professional requirements according to the DM37/2008 that, under its responsibility, to ensure compliance with the rules of good technique.
- you need to keep in mind all laws and national, regional, provincial and municipal laws of the country in which you installed the device
- check that the floor is not flammable: if necessary use a suitable platform
- in the room where the generator must be installed to heat must not pre-exist or be installed with an extractor hood or ventilation ducts of the collective type. Should these devices be located in adjacent rooms communicating with the installation, and 'prohibited the simultaneous use of the heat generator, where there is a risk that one of the two rooms being placed in depression than the other

Rear flue connection

The stove is supplied by default with a rear smoke flue. Use silicone and the specific screws to fasten the joint found inside the combustion chamber. A T-shaped tube must be positioned on this joint to allow inspection of the smoke duct. (Fig.1 a-b)

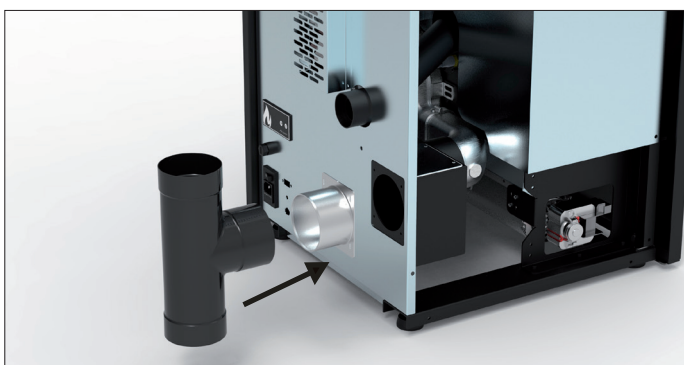

Fig. 1a

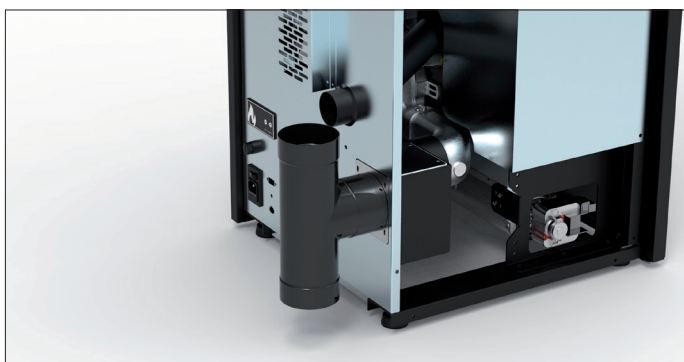

Fig. 1b

Upper flue connection

Since the stove is prepared for the rear smoke exhaust, the left hand side must be removed and unscrew the closure plate found on the upper part of the smoke box. (Fig.2)



Fig. 2

Position the flange and the gasket on the rear chamber of the smoke box. This flange can be used as the inspection chamber. The joint supplied with the stove must be fastened using the specific screws and high temperature silicone on the upper part of the smoke box. (Fig.3)

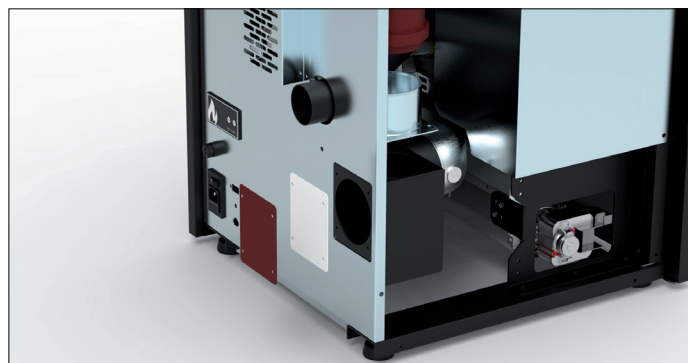

Fig. 3

You can install the smoke exhaust tube without using the T-joint. (Fig.4)

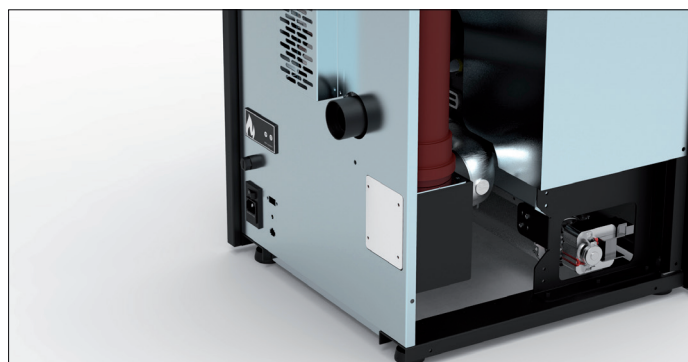

Fig. 4

Flue

The following instructions have the purpose of giving instructions on installation of a good flue, however they do not replace in any way the standards in force of which a qualified builder must be aware. The stove manufacturer cannot be held in any way liable in civil or criminal terms for poor operation of the stove due to a wrongly sized flue and/or non-compliance with legislation in force, which must be complied with. The flue must be built to standard and category $\geq T200$ or higher, with a vertical progression without choking, resistant to condensate and resistant to fire caused by soot. It must be externally insulated to avoid smoke cooling and it must have a condensate drain. If the flue is a cement shaft, it must be ducted. The flue must be inspected for cleaning and must also be distanced from flammable and/or combustible materials.

The minimum distances to comply with from any chimneys or reflux zones are outlined below.

Check the negative pressure between the flue and the environment installed comply with the instructions in the technical characteristics. The minimum height of the flue is 3.5 metres and must have an internal section that allows compliance with these requirements and however not over 100mm. Check the correct configurations using UNI EN 13384-1.

The flue must always be clean. Any soot residue reduces the section of the flue which would compromise draught and the soot could catch fire. Have a professional chimney sweep clean the flue and the chimney at least once a year and before switching on the generator after periods of inactivity. Lack of cleaning will negatively impact correct operation of the equipment.



Installation of the flue is not permitted shared with other equipment.

Chimney

The opening area for smoke evacuation must be at least double the section of the flue and must prevent snow and animals entering. The measurement of the opening in the atmosphere must be outside the backflow zone caused by the shape of the roof and/or any obstacles found nearby. Pay attention to the presence of skylights and dormer windows.

30° ROOF

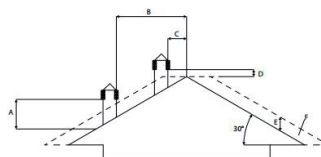

- A = MIN. 1,30 metri
- B = DISTANZA > 1,50 metri
- C = DISTANZA < 1,50 metri
- D = 0,50 metri OLTRE IL COLMO
- E = 0,80 metri
- F = BACKFLOW ZONE

45° ROOF

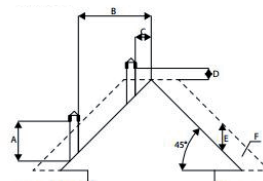

- A = MIN. 2,00 m
- B = DISTANZA > 1,30 metri
- C = DISTANZA < 1,30 metri
- D = 0,50 m OVER THE RIDGE
- E = 1,50 metri
- F = BACKFLOW ZONE

60° ROOF

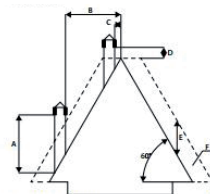

- A = MIN. 2,60 m
- B = DISTANZA > 1,20 m
- C = DISTANZA < 1,20 m
- D = 0,50 m OVER THE RIDGE
- E = 2,10 m
- F = BACKFLOW ZONE

FLAT ROOF

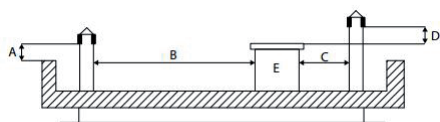

- A = MIN. 0,50 m
- B = DISTANZA > 2,00 m
- C = DISTANZA < 2,00 m
- D = 0,50 metri
- E = TECHNICAL VOLUME

15° ROOF

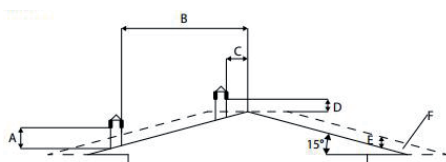

- A = MIN. 1,00 m
- B = DISTANZA > 1,85 m
- C = DISTANZA < 1,85 m
- D = 0,50 m OVER THE RIDGE
- E = 0,50 metri
- F = BACKFLOW ZONE

Flue connection

The joint between the stove and the flue must be installed using suitable tubes (min. T200). Use is forbidden of flexible metal tubes, in cement fibre or aluminium. The slope of the smoke duct must not have horizontal sections over 2 metres and must have a minimum 3% inclination. The first change of direction must take place after at least 1.5 metres of the vertical section. Inspect the base of the smoke duct

with periodic controls. It is forbidden to connect the same smoke duct on multiple equipment. Keep the smoke duct an adequate distance from any flammable parts or parts sensitive to heat. Refer to the instructions given by the manufacturer of the flue for the distances to respect.

Example of correct installation.

How to connect canalization (where present)

On the canalization outlet only, connect a tube for each duct with a diameter of 80mm with a maximum length of 8 linear metres. For each 45° curve, consider a loss of one metre of linear section (e.g. maximum distance without curves 8 metres; maximum distance with a 45° curve $8 - 1 = 7$ metres). You are advised to use tubes with a diameter of 80mm and with a smooth internal surface.

They must resist heat (you are advised to use at least a T200). Keep a distance from flammable and/or combustible objects (at least 50 cm) and from curtains and furniture.

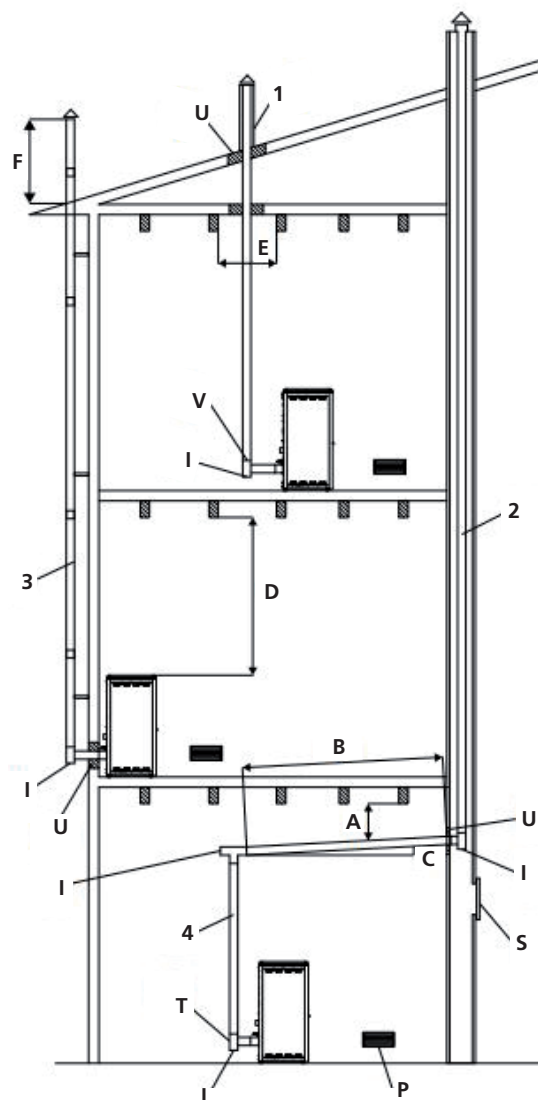

A= MINIMUM 40 MM
B= MASSIMUM 4 M
C= MINIMUM 3°
D= MINIMUM 400 MM
E= DIAMETER OF HOLE
F= SEE FIG. 2-3-4-5-6

U= INSULATION
V= POSSIBLE REDUCTION FROM 100 TO 80 MM
I= INSPECTION PLUG
S= INSPECTION DOOR
P= AIR INTAKE
T= T JOINT WITH INSPECTION PLUG

Pellet

The pellets are cylinders of compressed wood, produced from sawdust and wood processing (chips and sawdust), generally produced by sawmills and carpenters. The binding capacity of the lignin contained in wood, allows to obtain a compact product without adding additives and foreign chemicals to the wood, is therefore obtained a natural fuel with high yield.

The use of expired pellets or any other unsuitable material can damage parts of the thermostove and impair proper operation: this can lead to the termination of the guarantee, and its producer responsibility. With obvious floor capacity evaluation, in the installation premises, a maximum can be deposited of fuel, which corresponds to approx. 975kg of pellets.



For our products use pellets diameter 6 mm, length 30 mm and a maximum of 8% and A1 certified according to the UNI EN ISO 17225-2 standard. Keep the pellets away from heat sources and not in humid environments or with explosive atmosphere.

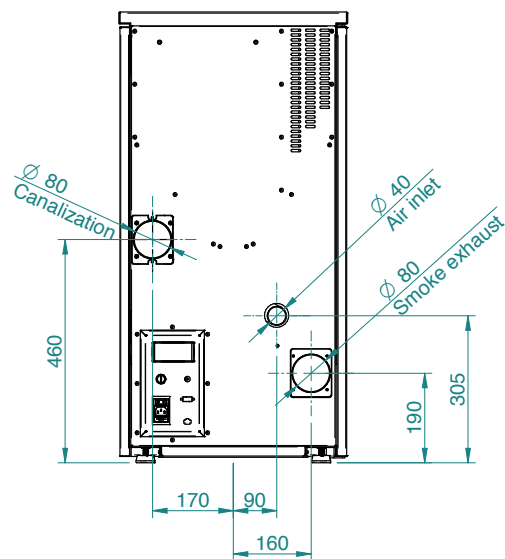
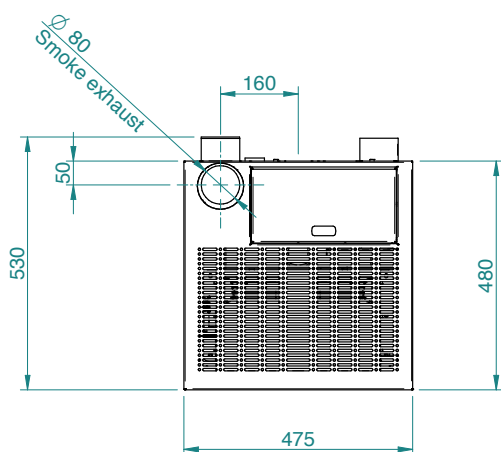
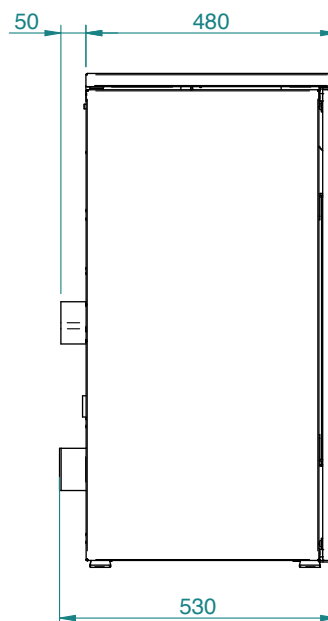
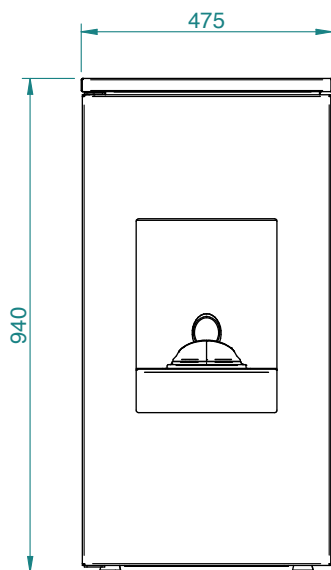

REMARKS:

- measurements are approximate and may vary based on to the aesthetics of the stove
- the positions of the tubes in the rear view are indicative and tolerance of +/- 10 mm
- measures with a tolerance of about 10 mm

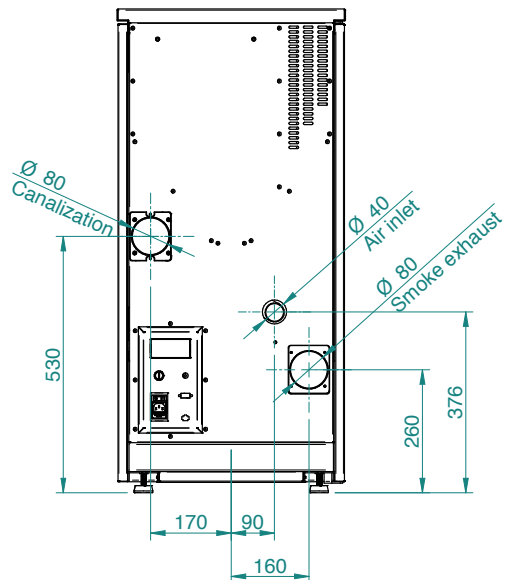
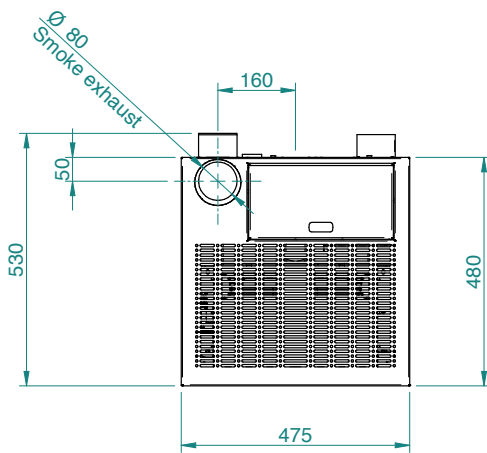
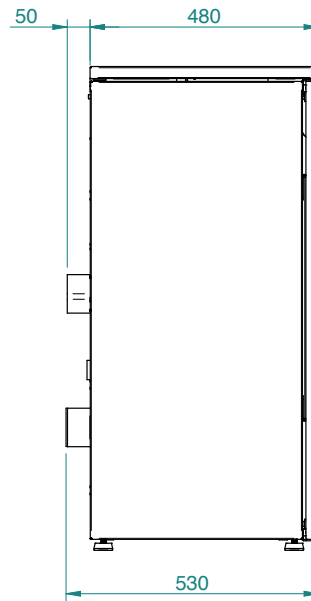
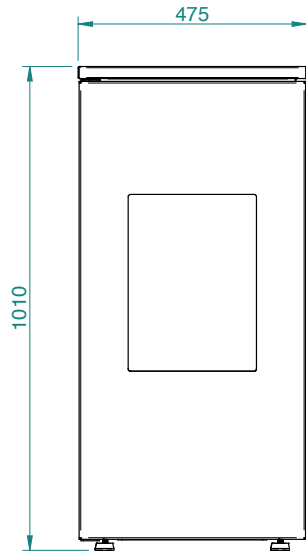

REMARKS:

- measurements are approximate and may vary based on to the aesthetics of the stove
- the positions of the tubes in the rear view are indicative and tolerance of +/- 10 mm
- measures with a tolerance of about 10 mm

PARAMETRO	UNITÀ DI MISURA	FUTURA 7-7C	FUTURA 9-9C	FUTURA 11-11C
Heat input	kW	7,9	9,6	11,8
Nominal heat output	kW	7,5	9	11
Reduced nominal heat output	kW	3,7	3,7	3,7
CO concentration at nominal reference (13% O ₂)	mg/m ³	25	21	16
CO concentration at reduced reference (13% O ₂)	mg/m ³	197	197	197
Nominal efficiency	%	95	94,2	93
Reduced efficiency	%	95	95	95
Average consumption (min-max)	Kg/h	0,8 - 1,65	0,8 - 1,99	0,8 - 2,45
Heated surface	mc	200	240	290
Flue gas rate (min-max)	g/s	3 - 4,2	3 - 5,2	3 - 6,6
Draft advised (min-max)	Pa	5-8	5-8	5-8
Flue gas temperature (min-max)	°C	76 - 102	76 - 113	76 - 128
Tank capacity	Kg	15	15	15
Diameter flue outlet tube	mm	80	80	80
Diameter air intake	mm	40	40	40
Nominal voltage	V	230	230	230
Nominal frequency	Hz	50	50	50
Ignition power consumption	W	300	300	300
Electrical consumption max-min without canalization	W	40 - 22	48 - 22	58 - 22
Electrical consumption max-min with canalization	W	86 - 22	94 - 22	104 - 22
Weight	Kg	100	100	110
Indice efficienza energetica		134 (7) 133 (7C)	133 (9) 132 (9C)	131 (11/11C)
N° Test Report	K 2785 2019 T1			
Energy class	A ++			
Environmental decree n. 186 of 7/11/2017	★★★★☆			
Powders at (13% O ₂) Ref. nominal heat input	mg/m ³	10	10	10

It is recommended to control emissions after installation.

In order to achieve the test report results, please load the performance parameters retained by the manufacturer and the qualified technician. They will use these parameters once verified that, during the installation, it is possible to reproduce the laboratory conditions. This performance is only reached after 15/20 working hours at nominal power.

Maintenance and cleaning of the stove

Before effecting any maintenance operation or cleaning on the stove, take the following precautions:

- be sure that all parts of the stove are cold.
- be sure that the ashes are completely cold.
- be sure that the general switch is in the "OFF" position.
- be sure that the plug is pulled out of the socket to avoid accidental contact.
- once the maintenance phase is completed check that everything is in order as per before the intervention (the brazier is placed correctly).



Follow carefully the following cleaning instructions. Failure to follow these instructions could create problems with the operation of the stove.

Cleaning the brazier and brazier support

When the flame assumes a red colour or seems weak, and is accompanied by black smoke, this means that there are ash deposits or incrustations that do not permit the correct functioning of the stove and that must be removed. Remove the brazier every day by simply raising it from its slot; then clean out the ashes and eventual incrustations that may have formed, paying particular attention to liberating the holes by using a pointed tool (not included with the stove).

This operation is made particularly necessary before every lighting the first several times and above all if using pellets that differ from those supplied by our company. The frequency of this operation is determined by how frequently the stove is used and the choice of pellets.

It is also a good idea to check the brazier support, vacuuming the eventual ash present.

To guarantee the high efficiency of the stove, you are advised to clean it with a vacuum cleaner, including the compartment that allows access to the lower part of the exchange tubes, removing ash residue that accumulates (Fig. 1).

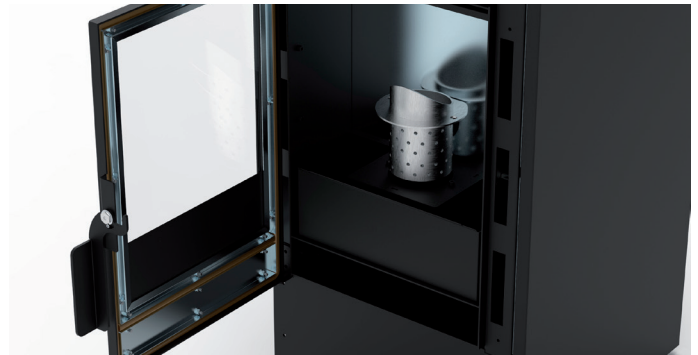

Ash box

Open the door and use a vacuum to remove all the ash deposited inside the ash box. This operation must be performed more or less frequently depending on the quality of the pellets used.

Cleaning the glass

In the arc of a few hours, the glass will form a greyish film which you can clean on first switch off of the stove. Blackening of the glass also depends on the quality and quantity of the pellets used.

Cleaning the glass should be done when the stove is cold with products recommended and tested by our company.

When performing this operation, always check that the grey seal around the glass is in a good state; failure to check the efficiency of this gasket can compromise the function of the stove.

Poor quality pellets can, in any case, cause the glass to become dirty.



If the glass is broken, do not attempt to light the stove.

Cleaning the surfaces

To clean the surfaces, use a rag dampened with water or with water and a neutral detergent.



The use of aggressive detergents or thinners can damage the surfaces of the stove. Before using any detergent it is advisable to try it on a small section out of sight or contact the Authorized Assistance Centre for information regarding the product.

Cleaning the metal parts

To clean the metal parts of the stove, use a soft cloth dampened with water. Never clean the metal

parts with alcohol, thinners, petrol, acetone or other degreasing substances. If such substances are used, our company declines any responsibility. Eventual variations in the colour of the metal parts can be caused by an incorrect use of the stove.



It is necessary to daily clean the brazier and often clean the ash box. The lack of cleanliness can prevent the starting of the stove, causing damages to the stove itself and to the environment (possible emission of unbrunt material and soot). Do not re-use the pellet possibly remained in the brazier due to no starting-up.

CLEANING BY TECHNICIANS

Check every year

Clean the combustion chamber

1. Open the door and remove the ash pan and the grate, cleaning any residue from it.



2. Remove the screws fastening the rear plate.

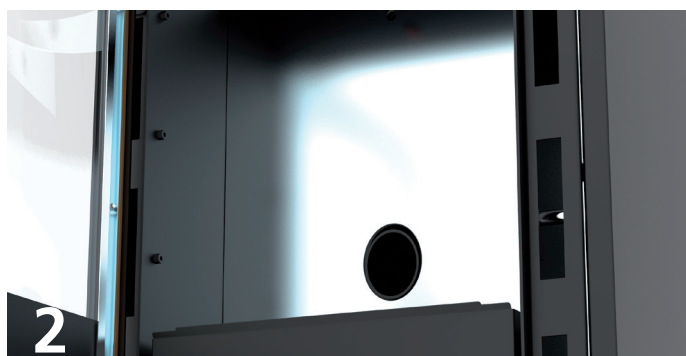

3. Push the plate upwards and turn it frontally to remove it.

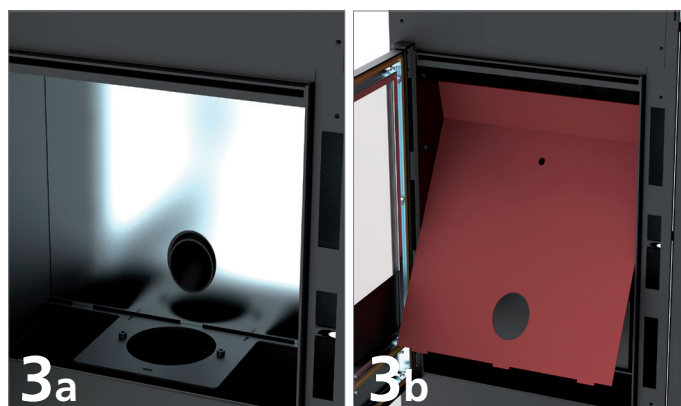

4. With the specific T tool, scrape the exchange tubes which are now accessible and remove everything with a vacuum cleaner.

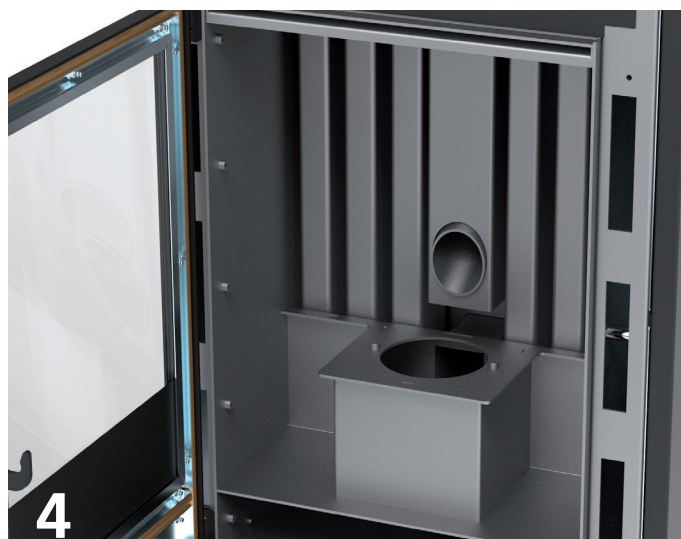

5. Re-assemble all the components, repeating the operations in the opposite order.

6. Remove and clean the T joint behind the stove.

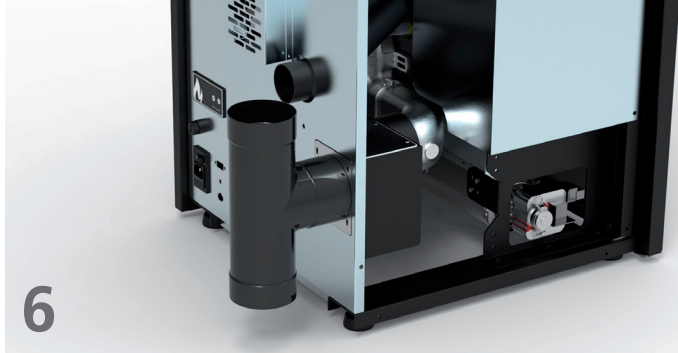

7. With a vertical fume exhaust, the smoke box is used as a T joint, and you must therefore remove the rear plate of the fume box and clean the chamber with a vacuum cleaner.

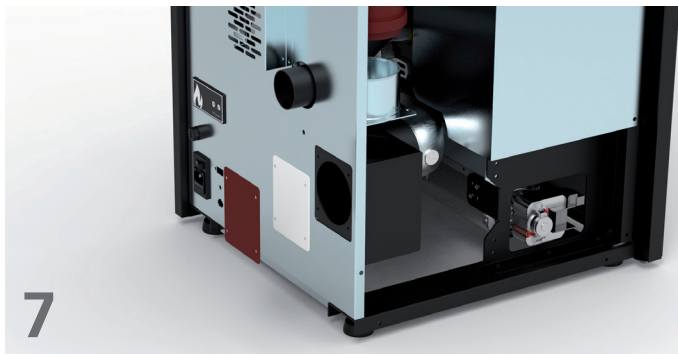

Cleaning the clearing system

Until a reasonable experience is acquired regarding the operating conditions, it is advisable to perform this maintenance on at least a monthly basis.

- remove the electrical feed cable;
- remove the cap from the T-joint and proceed with the cleaning of the ducts. If necessary, at least for the first few times, call in qualified personnel;
- carefully clean the smoke discharge system: for this, contact a professional chimney sweep;
- once a year clean the dust, cobwebs, etc. from the zone behind the internal covering panels, paying particular attention to the fans.

Cleaning the fans

The stove is furnished with fans (environmental and smoke) positioned at the rear and below the stove. Eventual deposits of dust or ash on the blades of the fan can cause an imbalance in the fans leading to noisy performance. It is, therefore, necessary to clean the fans at least once a year. Since said operation requires dismantling several parts of the stove, have the fans cleaned only by our Technical Assistance Centre.

Season end cleaning

At the end of the season, when the stove will not be used for some time, it is advisable to perform a thorough and general cleaning:

- Remove all the pellets from the container and the screw feeder;
- Carefully clean the brazier, the brazier support, the combustion chamber and the ash box.

Once the preceding points have been observed, it only means that the state of the stove has been verified. It is necessary to thoroughly clean the smoke discharge tube or flue and check the condition of the basket. If necessary, order a new one from our Authorized Assistance Centre.

If necessary, lubricate the hinges of the door and the handle. Also check the ceramic fibre cord near the glass, on the internal wall of the door; if it is worn or too dry, order a new one from the Authorized Assistance Centre.

Maintenance and cleaning



All cleaning of all parts must be carried out with the stove completely cold and unplugged to avoid burns and thermal shock. The stove does not need much maintenance if used with certified quality pellet. The need for maintenance varies depending on the conditions of use (switching on and off repeatedly) and depending on the performance required.

Parts	Everyday	Every 2-3 days	Every week	Every 15 days	Every 30 days	Every 60-90 days	Every year / 1200-1400 h
Brazier	◇						
Cleaning ash collection compartment		◇					
Cleaning the door and glass		◇					
Cleaning the interior heat exchanger / smoke fan compartment						•	
Cleaning complete exchanger							•
Clean "T" to exhaust						•	
Flue							•
Door gasket ash						•	
Internal parts							•
Flue pipe							•
Electromechanical components							•

◇ by the user

• by the authorised qualified technical assistance



Every 1200 hours of work the electronic board sends a warning signal and the display will show "SERVICE". This indicates the need for a thorough cleaning of the stove by a CAT. The lack of such cleaning could result in failure of the stove and poor combustion, thereby resulting in a lower yield.

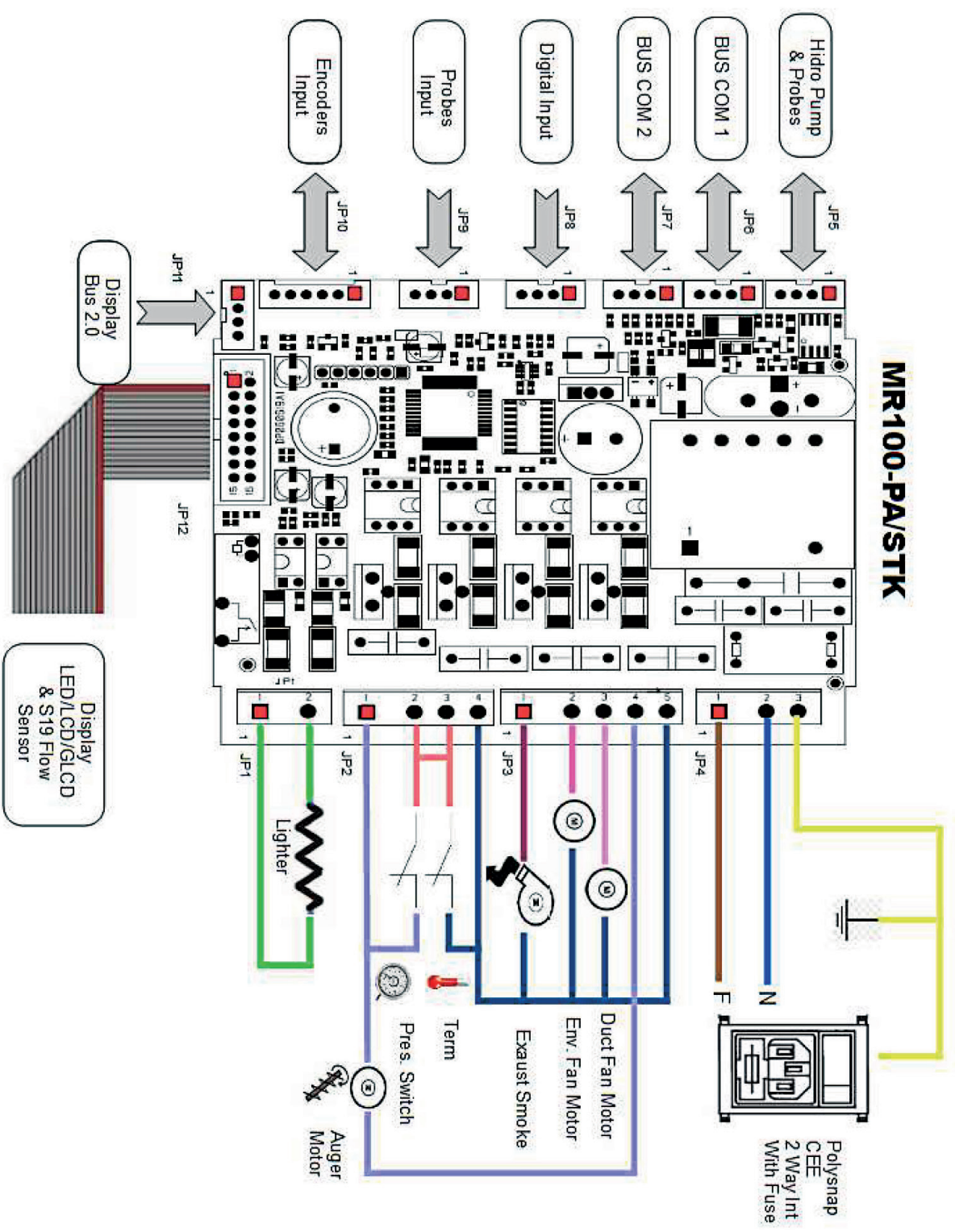

Safety devices



Pressure switch: monitors depression in the smoke duct. It is designed to shut down the pellet feed screw in the event of an obstructed flue or significant back-pressure in the presence of wind. At the time of the pressure switch will show "ALARDEP-FAIL".

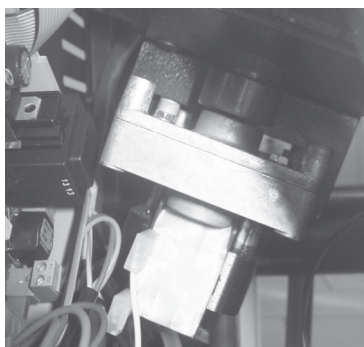

Reduction motor: if the motor stops, the thermostat continues to function until the flame goes out for lack of fuel, and until it has cooled down to the minimum level.

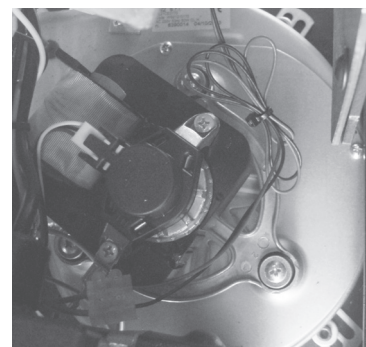

Flue gas temperature sensor: thermocouple that measures the temperature of the fumes while keeping the operation or shuts the thermostat when the flue gas temperature drops below the preset value.



Electrical safety: the stove is protected against violent surges of current (ex. lightnings) by the main fuse 4 A which is located on the control panel at the rear of the thermostat. Other fuses to protect the electronic boards are to be found on the boards themselves.



Pellets temperature safety: In the rare event there is a too high temperature in the tank, the thermostat for pellets safety with manual reset creates an alarm "ALAR-SIC-FAIL" stopping the pellet boiler stove. You need to reset the system working on the device placed on the back of the thermostat.



Room thermostat: the room thermostat detects the present temperature in the room. When it detects the set temperature on the display, the stove will go into operation in ECO ie hold function to save fuel. The room thermostat should be spread so as not to be conditioned by the temperature of the body stove.



Tampering with the safety devices is prohibited. It is only after eliminating the cause which gave rise to the intervention of the safety system, that it is possible to relight the stove and thus reset the automatic operation of the sensor. To understand which anomaly has occurred, consult this manual at paragraph relating to alarms which explains what to do based on the alarm message the stove display.



All repairs must be carried out exclusively by a specialised technician, with the stove completely cold and the electric plug pulled out. Is prohibited from any unauthorized modification to the device and the replacement of parts with other non-original. The operations marked in bold type must be carried out by specialised personnel.

Any inconvenience and solutions

Given that all stoves are tested in their parts handling and work and therefore are delivered in perfect physical condition and operation, it should be remembered that the transport, unloading, handling, misuse or poor maintenance, can be causes of drawbacks.

The main problems may be solved by reading the table below.

If after doing as hereinafter described the problem is not resolved, contact your authorized service center.

ANOMALIES	POSSIBLE CAUSES	REMEDIES
Display off and buttons are not working	<ol style="list-style-type: none"> 1. Power failure in the network 2. Switch back off 3. Fuse board interrupted 4. Card defective 	<ol style="list-style-type: none"> 1. Check that the power cord is connected 2. Use the switch back to operate it 3. Contact an authorized service center 4. Contact an authorized service center
Remote inefficient	<ol style="list-style-type: none"> 1. Too far from the stove 2. No batteries in the remote 3. The remote control is broken 	<ol style="list-style-type: none"> 1. Move closer to the stove 2. Check and change the batteries 3. Replace the remote control
Failure to ignite the stove	<ol style="list-style-type: none"> 1. Excessive accumulation of ash in the grate 2. Incorrect ignition procedure 	<ol style="list-style-type: none"> 1. Clean the grate 2. Repeat the ignition procedure. If persists, contact your authorized service center
Smoke comes from the grill	<ol style="list-style-type: none"> 1. Accidental electrical blackout 	<ol style="list-style-type: none"> 1. In case of ignition phase interrupted and momentary interruption of the fan, can occur slight amount of smoke
Hot air fan is not working	<ol style="list-style-type: none"> 1. The stove has not yet been heated 	<ol style="list-style-type: none"> 1. Wait until the conclusion of the ignition cycle. Arrived in temperature, the fan will start automatically. If the problem persists, contact your authorized service center.

<p>The stove does not turn on automatically</p>	<ol style="list-style-type: none"> 1. The tank is empty. 2. The resistance does not reach the temperature 3. Resistance damaged 4. The pellet drops 5. Screw motor defective 6. The grate is not in place or is dirty 7. Obstruction of nests or foreign bodies in the chimney or fireplace 8. Check operation of the glow plug 9. The ash drawer is not closed properly 10. Clogged flue and chimney 11. Smoke extractor not working 12. Temperature sensor defective 13. Pellet wet 	<ol style="list-style-type: none"> 1. Fill the tank with pellets 2. Check the electrical wiring and fuses, replace if the resistance is broken 3. Replace the resistance 4. It is recommended to unplug the power supply before: <ul style="list-style-type: none"> - check that the pellet is not caught in the chute - check that the cochlea is not blocked by dirt - check the seal of the pellet-door 5. Contact an authorized service center 6. Check that the hole in the brazier matches the glow plug, clean brazier 7. Remove any foreign body from the chimney or flue pipe 8. Make sure that there is power. Replace the spark plug if burned 9. Close the drawer ashtray 10. Perform periodic cleaning 11. Check the operation of the extractor flue 12. Contact an authorized service center 13. Make sure the place of stowage pellet and replace it with a handful of dry pellets
<p>Lock the stove. Pellets not being fed into the combustion chamber</p>	<ol style="list-style-type: none"> 1. The tank is empty 2. The cochlea is no pellet 3. Technical problem of the cochlea 4. Reduction motor failure 5. Electronic board faulty 	<ol style="list-style-type: none"> 1. Load the pellets in the tank. 2. Fill the tank and proceed as instructed before ignition stove 3. IT IS RECOMMENDED to unplug the power supply before: <ul style="list-style-type: none"> - empty the tank and manually free the auger from obstructions (sawdust) - release the slide from obstructions - remove the dust accumulation of pellets in the bottom of the tank 4. Replace the reduction motor 5. Replace the electronic board
<p>The stove runs for a few minutes and then turn off</p>	<ol style="list-style-type: none"> 1. Lighting cycle not completed 2. Temporary failure of electricity 3. Probes fumes defective or broken or not inserted 	<ol style="list-style-type: none"> 1. Re-run power 2. Re-run power 3. Check and replace sensors
<p>Fume extraction fan does not stop</p>	<ol style="list-style-type: none"> 1. The stove has not yet cooled 	<ol style="list-style-type: none"> 1. Allow the stove to cool. Only after cooling fan will stop. If the problem persists, contact your authorized service center

<p>The braziere is clogged, burning irregular, door glass gets dirty, the flame is long, reddish and weak</p>	<ol style="list-style-type: none"> 1. Flue with presence of stretches too long or clogged 2. Too pellet 3. Excessive pellet or ash deposits in the brazier 4. The brazier is not found in its slot 5. Wind contrary to the exhaust flow 6. Insufficient combustion air 7. You changed the type of pellets used 8. Smoke extractor motor broken 9. Door closed incorrectly 	<ol style="list-style-type: none"> 1. Perform periodic cleaning. See paragraph stove installation in the user manual. Check chimney cleaning 2. Decrease in the parameters the charge level of the pellets 3. Clean the brazier after waiting for the total shutdown of the stove. If you repeat contact your Authorized Service Center 4. Check that the hole in the brazier matches the glow plug 5. Check the chimney cap windproof and / or possibly install it 6. Check the correct position of the brazier, its cleanliness and check that the air intake in both free environment, verify the status of the door seal, increase the level in the parameter relative to the speed of the fan exhaust fumes. Contact your Authorized Service Center 7. Check the quality of the pellets. Contact your Authorized Service Center 8. Increase the level in the parameters relating to the speed of the fan exhaust fumes. Check and eventually replace motor 9. Check that the glass is sealed and the seal guarantees tightness
<p>Smell of smoke in the environment. Turning off the stove.</p>	<ol style="list-style-type: none"> 1. Poor combustion 2. Malfunction of fan fumes 3. Installation of the flue performed incorrectly 4. Clogged chimney 	<ol style="list-style-type: none"> 1. Contact your Authorized Service Center 2. Contact your Authorized Service Center 3. Contact your Authorized Service Center 4. Contact your Authorized Service Center
<p>In the automatic position the stove always runs at full power</p>	<ol style="list-style-type: none"> 1. Room thermostat set to maximum 2. Significant temperature sensor failure 3. Control panel defective or broken 	<ol style="list-style-type: none"> 1. Reset the thermostat temperature 2. Check the operation of the sensor and replace if necessary 3. Check the control panel and replace if necessary
<p>The engine smoke extraction does not work</p>	<ol style="list-style-type: none"> 1. The stove has no voltage 2. The motor is broken 3. The board is defective 4. The control panel has failed 	<ol style="list-style-type: none"> 1. Check the supply voltage and the protection fuse. 2. Check the motor and capacitor and replace if necessary. 3. Replace the circuit board. 4. Replace the control panel.

<p>The fire goes out or the stove stops automatically</p>	<ol style="list-style-type: none"> 1. The pellet tank is empty 2. No power 3. Pellets not being fed 4. Excessive deposit of ashes in the grate 5. Intervention probe temperature safety of the pellet 6. Cochlea blocked by dirt 7. The door is not closed properly or gaskets worn 8. Pellet inadequate 9. Low pellet 10. Chimney or drain clogged with nests or foreign bodies 11. Pressure switch cuts 12. Smoke extraction motor failure 13. Alarm active 	<ol style="list-style-type: none"> 1. Fill the tank with pellets 2. Check plug and presence electricity 3. Fill the tank with pellets 4. Clean the brazier 5. Let the stove cool down completely, reset the manual reset and restart the stove. If the problem persists, contact your authorized service representative 6. Pull the plug, empty the tank, remove any foreign objects 7. Close the door or replace the gaskets with original 8. Change the type of pellet recommended by the manufacturer. Sometimes, depending on the type, the stage of adjustment of the parameters need to vary the level relating to the loading of pellets 9. Increase the level in the parameter for the pellet feed. To check the flow of fuel from technical authorized 10. Eliminate all foreign matter from the chimney Clean the smoke duct. Perform periodic cleaning. 11. Verify potential smoke duct is blocked and if the pressure switch is working properly 12. Check and replace the motor if necessary 13. See paragraph alarms
<p>The air fan convention (ambient air) never stops</p>	<ol style="list-style-type: none"> 1. Temperature sensor temperature control defective or broken 2. Smoke probe fails 	<ol style="list-style-type: none"> 1. Check the operation of the sensor and replace if necessary 2. Replace smoke probe
<p>The stove does not light.</p>	<ol style="list-style-type: none"> 1. Lack of electricity 2. Probe pellets in bulk 3. Fuse blown 4. Pressure switch broken (lockout indicated) 5. Smoke outlet or duct clogged 	<ol style="list-style-type: none"> 1. Check that the electrical outlet is plugged in and the power switch to "I" 2. Lockout by resetting the rear thermostat, replace the thermostat if it happens again 3. Replace the fuse 4. Replace the pressure 5. Clean the smoke outlet and / or smoke duct



The manufacturer of the stove any liability and will void the warranty terms of the product for any inconvenience caused by not following the rules described above. Any work of service center will be borne by the applicant if they are not complied with these instructions.

GENERAL GUARANTEE

All products are subject to accurate testing and are covered by warranty for 24 months from the date of purchase, documented by invoice or purchase receipt that will be presented to authorized technicians. If the document does not show up, it will be invalidate the right of the owner of the appliance. Warranty means the replacement or repair of parts of the appliance that are defective at source due to manufacturing faults.

1. Warranty covering manufacturing defects and defects in material declines:

- for unauthorized personnel work;
- for damage caused by transport or for causes not attributable to the manufacturer;
- for incorrect installation;
- for incorrect electrical connection;
- for periodic maintenance not performed;
- for outdoor accidents (lightning, floods, etc ...);
- for incorrect use and maintenance.

2. Complete replacement of the machine can only take place following the unquestionable decision by the manufacturer in special cases

3. The Company declares no responsibility for any damage that may, directly or indirectly, result in persons, things or animals as a result of non-observance of the instructions in the Instructions book and in particular concerning the installation, use and maintenance of the appliance.

GUARANTEE LIMITATIONS

Limited Warranty covers manufacturing defects, provided that the product has not been damaged by improper use, improper handling, incorrect connection, tampering, and installation errors. The following components are covered by a twelve months warranty:

- combustion burners;
- resistance.

They are not covered by warranty:

- the glass of the door;
- general gasket and fiber door;
- painting;
- tiles;
- the remote control
- Internal sides
- Any damage caused by inadequate installation and / or shortages of the consumer.

The images are purely indicative and may not match the reality of the product. Pictures are only exemplary and they are needed to understand how the product works.

This warranty excludes all the malfunctions and/or damage to equipment which is due to the following causes:

- damage caused by transport and/or movement
- all the parts resulting as faulty due to negligence or carelessness during use, wrong maintenance, installation non-compliant with manufacturer specifications (always refer to the installation and use manual of the equipment)
- wrong dimensioning compared to use or faulty installation, i.e. non-implementation of the measures necessary to guarantee execution to standard
- improper overheating of the equipment, i.e. use of fuel incompatible with the types and quantities indicated on the instructions supplied
- further damage caused by wrong user interventions in an attempt to resolve the initial fault
- aggravated damage caused by further use of the equipment by the user once the defect is noticed
- in the presence of possible corrosion, scale or breakages caused by stray current, condensate, aggression or acidity of the water, descaling treatments carried out incorrectly, no water, sludge or limescale deposits
- inefficiency of the chimneys, flues, or parts of the system on which the equipment depends
- damage caused by tampering with the equipment, atmospheric agents, natural disasters, vandalism, electrical discharges, fire, faulty electrical and/or hydraulic system
- Lack of annual maintenance of the stove, by an authorised technician or qualified staff, will cause loss of warranty.